



Wire Harness Installation Instructions

For Installing:

**#10127 Customizable Mopar Chassis Harness
21 Circuit**

Manual #90542

Painless Performance Products, LLC

2501 Ludelle Street

Fort Worth, TX 76105-1036

800-423-9696 phone – 817-244-4024 fax

Web Site: www.painlessperformance.com

E-Mail: painless@painlessperformance.com

If you have any questions concerning the installation of this product, feel free to call **Painless Performance Products'** tech line at 1-800-423-9696. Calls are answered from 8am to 5pm central time, Monday thru Thursday, 8am-4:30pm Friday, except holidays.

Here we have provided you with accurate instructions for the installation of this product. However, if you have comments/suggestions concerning these instructions, please call or email us (our contact information can be found at the top of this page or online at **www.painlessperformance.com**). We sincerely appreciate your business.

Painless Performance Products, LLC shall in no event be liable in contract or tort (including negligence) for special, indirect, incidental, or consequential damages, such as but not limited to, loss of property, or any other damages, costs or expenses which might be claimed as the result of the use or failure of the goods sold hereby, except only the cost of repair or replacement.

Should you damage or lose part of your manual, a full color copy of these instructions can be found online at www.painlessperformance.com

Installation Manual: **90542**

1ST Edition: January 13, 2014

Copyright © 2005 by Painless Performance Products, LLC

TABLE OF CONTENTS

List of Figures.....	i
List of Tables.....	4
List of Diagrams.....	4
1.0 Introduction.....	4
2.0 About These Instructions.....	5
3.0 Contents Of The Painless Wire Harness Kit.....	5
4.0 Tools Needed.....	6
5.0 Pre-Installation and General Harness Routing Guidelines.....	6
6.0 Harness General Installation Instructions.....	7
6.1 Rough Installation.....	7
6.2 Harness Attachment.....	7
6.3 Grounding the Automobile.....	8
6.4 Terminal Installation and Making Connections.....	8
6.5 Testing the System.....	8
7.0 Mopar - Specific Circuit Connections.....	9
7.1 Mopar Alternator.....	9
7.2 Mopar Ignition System.....	9
7.3 Steering Column Wiring - Turn Signal Connections.....	12
7.4 Steering Column Wiring - Ignition Switch Connections.....	12
8.0 All Makes - Specific Circuit Connections.....	13
8.1 Generator Charging System.....	13
8.2 Generator to Alternator Conversion.....	13
8.3 Connecting to Ammeter and the Maxi-Fuse.....	14
8.4 Interior Lighting.....	14
8.5 Headlight Section "A".....	15
8.6 Headlight Section "B".....	16
8.7 Instrument Panel Wiring.....	16
8.8 Brake Light Switch.....	16
8.9 Tail Section Wiring.....	17
8.10 Helpful Hints for Tail Section Wiring.....	18
9.0 Wire Connection Index	19

LIST OF FIGURES

Figure 3.1 Painless Harness Kt.....	5
Figure 7.1A Mopar Alternator.....	9
Figure 7.1B High Output Wire.....	10
Figure 7.2A Mopar Ignition System.....	11
Figure 7.2B Mopar Electronic Ignition with Dual Ballast Resistor.....	11
Figure 7.3 Turn Signal Terminal.....	12
Figure 8.1 Generator Charging System.....	13
Figure 8.2 Ammeter and Maxi-Fuse.....	13
Figure 8.3 Interior Lighting.....	14
Figure 8.4A Typical Fan Relay Installation.....	15
Figure 8.4B Headlight Section "A" Wiring.....	15
Figure 8.5A Dual Head Lamp Connections.....	16
Figure 8.5B Dimmer Switches.....	16
Figure 8.7A Integrated Brake Light and	17
Figure 8.7b Separate Turn/Brake Lights	18
Figure 8.10A Lamp Socket Terminal.....	18

Figure 8.10B Lamp Socket Assembly.....	18
--	----

LIST OF TABLES

Table 7-1	Mopar Ignition and Turn Signal Wiring	12
Table 9-1	Wire Connection Index (1 of 2).....	20
Table 9-1	Wire Connection Index (2 of 2).....	21

LIST OF DIAGRAMS

Diagram 1	Instrument Panel Section Wiring.....	22
Diagram 2	Engine Wiring.....	23

1.0 INTRODUCTION

You have purchased what we at Painless Performance Products believe to be the most up-to-date and easiest-to-install automotive wire harness on the market. It is designed for easy installation, even if you have no electrical experience.

All kits have a built-in-anti-theft feature. Removing the fuse labeled "coil" from the fuse block will prevent the vehicle from starting.

The proper fuses have been pre-installed in the fuse block. In addition, all wires are color-coded. This will help you identify the different circuits during installation and later on if additions to the overall system are necessary. For fuse specifications and wire color designations, see **Section 9.0**.

All wire is 600 volt, 125°C, TXL. Standard automotive wire is GPT, 300 volt, 80°C, with PVC insulation.

This complete automobile wiring system has been designed with three major groups incorporated into it:

ENGINE/HEADLIGHT GROUP

Includes high beam, low beam, park, right turn, left turn, electric fan, horn, starter solenoid and battery feed, alternator and alternator exciter wire, distributor, water temperature, oil pressure, and air conditioning.

DASH GROUP

Includes wires to connect gauges, indicator lights, and switches to their proper sources.

REAR LIGHT GROUP

Includes tail lights, dome lights (see Paragraph 8.4.2), left and right turn signals, brake lights, and fuel sender.

- Installation requires four (4) easy steps:
1. Mount the fuse block
 2. Route the wires
 3. Cut off the excess wire
 4. Terminate the wires

2.0 ABOUT THESE INSTRUCTIONS

The contents of these instructions are divided into major **Sections**, as follows:

- 1.0 Introduction
- 2.0 About These Instructions
- 3.0 Contents of Painless Wire Harness Kit
- 4.0 Tools Needed
- 5.0 Pre-Installation and General Harness Routing Guidelines
- 6.0 General Harness Installation Instructions
- 7.0 Mopar - Specific Circuit Connection Details
- 8.0 All Makes - Specific Circuit Connection Details
- 9.0 Wire Connection Index and Fuse Requirements

Sections are divided into subsections and **Paragraphs**. Throughout these instructions, the **Figure** numbers refer to illustrations and the **Table** numbers refer to information in table form. These are located in Sections or Paragraphs corresponding to the number. Always pay special and careful attention to any *Notes*, especially those in the Tables, and any text marked **Caution**.

3.0 CONTENTS OF THE PAINLESS WIRE HARNESS KIT

Refer to **Figure 3-1** to take inventory. See that you have everything you're supposed to have in this kit. If anything is missing, contact the dealer where you obtained the kit or Painless Performance at (800) 423-9696. The Painless Wire Harness Kit should contain the following items:

- A** The Main Wire Harness, with the Fuse Block wired in and fuses installed.
- B** Headlamp Connector Kit. (extra pre-made Headlamp pigtails are available separately under P/N 80300.)
- C** Maxi Fuse
- D** Firewall Grommet (large)
- E** 2 Fender Well Grommets (for Headlamps)
- F** 2 packages of Nylon Tie Wraps
- G** Parts Box, containing Terminals, Splices, etc. This booklet, P/N 90542 Painless Wiring Manual.

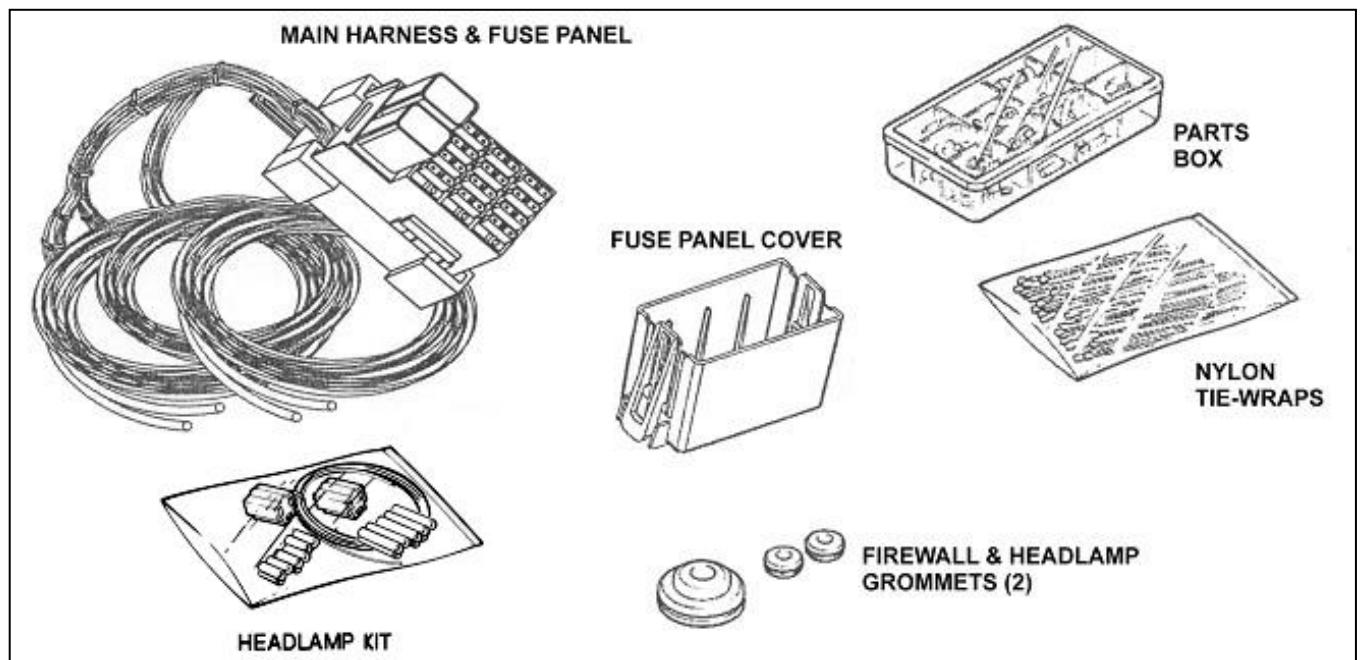

Figure 3-1 Painless Wire Harness Kit

4.0 TOOLS NEEDED

In addition to your regular tools, you will need, at least, the following tools:

Crimping Tool *Note: Use a quality tool to avoid over-crimping.*
Wire Stripper
Test Light or Volt Meter
Electric Drill
1-1/4" Hole Saw
Small (10 amp or less) Battery Charger

5.0 PRE-INSTALLATION AND GENERAL HARNESS ROUTING GUIDELINES

The installation of your wire harness mainly consists in two parts:

- The physical routing and securing of the wire harness, wires, and groups.
- The proper connection of the individual circuits.

These two major tasks are not separate steps, but are integrated together. That is, you will route some wires and make some connections, route some more wire and make some more connections.

We cannot tell you how to physically route the harness in your automobile. That depends a great deal upon the particular make/model of automobile and to what extent you want to secure and conceal the harness. We do offer some general guidelines and routing practices starting in **Section 5.2**, GENERAL installation instructions in **Section 6.0**, and precise instructions concerning the electrical connections you will have to make in beginning in **Section 7.0**. To help you begin thinking through the installation of your wire harness, read the following sections:

- 5.1** Familiarize yourself with the harness by locating each of the harness sections in the following list. (Whenever a particular harness section is referred to in these instructions it is shown "all caps": ENGINE SECTION A)

ACCESSORY SECTION SWITCHES	TURN SIGNAL SECTION
ACCESSORY SECTION B+	HEADLIGHT SECTION A
DIMMER SWITCH SECTION	HEADLIGHT SECTION B
ENGINE SECTION	IGNITION SWITCH SECTION
ENGINE SECTION A (Single, 10 ga. red wire)	INSTRUMENT PANEL SECTION
ENGINE SECTION A	RADIO SECTION
TAIL SECTION	HAZARD SWITCH SECTION
PANEL LIGHT SECTION	

*Note: For complete information concerning the individual circuits and wires that make up the harness SECTIONS, see **Section 9.0**.*

- 5.2** Decide where the fuse block will be mounted. The Painless Wire Harness is designed for the fuse block to be mounted on the driver's side, under the dash.
- 5.3** Decide which of the following circuits you will be using in your system and where the harness groups or wires will be routed:

ROUTING LOCATION AND PLACEMENT

Emergency Flashers	
Horn	
Dome Lights	
Lights	
Air Conditioner	
Electric Cooling Fan	
Coil	
Turn Signals	
Radio Ignition Switched Power	
Radio Constant Power	
Gauges	
Accessories	

5.4 Where will the following harness groups be routed?

Headlights	
Engine	
Dash	
Tail Lights	

- 5.5** A good exercise is to lay out the wire harness on the floor beside your automobile and identify all the SECTIONS. You will want to route the harness through and around open areas. Inside edges provide protection from hazards and also provide places for tie wraps, clips and other support.
- 5.6** Route the harness away from sharp edges, exhaust pipes, and hood, trunk and door hinges.
- 5.7** Plan where harness supports will be located. Allow enough slack at places where movement could occur (body to frame, frame to engine, etc.). Use a support every 12 inches unless the harness routes under the floor carpet.
- 5.8** At wire ends don't depend on the terminals to support the harness. The weight of the harness could cause terminals to disconnect or copper wire strands to break.
- 5.9** The wires should be bundled into groups. Use nylon ties, poly split loom, or tape.

6.0 HARNESS GENERAL INSTALLATION INSTRUCTIONS

6.1 Rough Installation

CAUTION: DISCONNECT THE POWER FROM YOUR VEHICLE BY REMOVING THE NEGATIVE (BLACK) BATTERY CABLE FROM THE BATTERY.

Note: Make no wire connections or permanent mounting of any kind at this time!

- 6.1.1** Position the fuse block in its mounting area.
- 6.1.2** Either use the included plate to cover the existing bulkhead hole or drill a 1-1/4" (1.25") hole near the fuse block for engine and headlight group wires to pass through (ENGINE SECTION, ENGINE SECTION A, SINGLE 10 GA. (Red wire #916), and HEADLIGHT SECTION A). If using the plate, install it on the "engine side" of the fire wall using the self tapping screws provided.
- 6.1.3** Install the Firewall grommet in the plate or the new hole you drilled. Route engine and headlight group wires through the grommet and position the harness groups in the areas decided upon in **Sections 5.3 and 5.1**.
- 6.1.4** Route dash group (ACCESSORY SECTION B+, ACCESSORY SECTION SWITCHES, HEADLIGHT SECTION B, INSTRUMENT PANEL SECTION and RADIO SECTION) upward to rear of dash and temporarily tie in place.
- 6.1.5** Position rear group, consisting of the TAIL SECTION, on floor pan area decided upon in **Sections 5.3 and 5.4**.

6.2 Harness Attachment

Note: Harness routing and shaping is and should be a time-consuming task. Taking your time will enhance the beauty of your installation. Please be patient and TAKE YOUR TIME!

- 6.2.1** Permanently mount the fuse block base with 2 self tapping screws supplied with this kit. (Note: The fuse block itself does not have to be grounded.)
- 6.2.2** Mold harness groups to the contour of floor pan, firewall, fender panels, and any other area where wires or harness groups are routed. Remember to route the harness away from sharp edges, exhaust pipes, hood, trunk and door hinges, etc.
- 6.2.3** Attach harness groups to your automobile with clips or ties starting at the fuse block and working toward the rubber grommet for the front groups and along the floor pan for the rear group. The dash wires should be routed out of the way of any under-dash obstacles, such as cowl vent, air conditioning, radio, etc.

Note: Do not tighten tie wraps and mounting devices at this time. Make all harness attachments LOOSELY.

- 6.2.4** When used every 1-1/2" or so on the visible areas of the harness, the plastic wire ties make a very attractive assembly. A tie installed in other areas every 6" or so will hold the wires in place nicely. Remember to take your time!

6.3 Grounding the Automobile

A perfectly and beautifully wired automobile will nevertheless have bugs and problems if everything is not properly grounded. Do not go to the careful effort of installing a quality wire harness only to neglect proper grounding.

Note: The Painless Wire Harness Kit includes no ground wire except the separate black wire for the two headlamp connectors. You must supply ground wire (14-16 gauge) for all circuits.

- 6.3.1 Connect a Ground Strap or Cable (minimum of 2 gauge) from the Negative Battery terminal to the engine block.
- 6.3.2 Connect a Ground Strap from the Engine to the chassis. **DO NOT RELY UPON THE MOTOR MOUNTS TO MAKE THIS CONNECTION.**
- 6.3.3 Connect a Ground Strap from the Engine to the Body.
- 6.3.4 If you have a fiberglass body you should install a terminal block to ground all your Gauges and Accessories. Ground the Terminal Block with at least a 12-gauge wire to the chassis.

6.4 Terminal Installation and Making Connections

Note: In the following steps you will be making the circuit connections. Before you start, you should carefully read **Sections 7.0 through 8.0**, as appropriate, and continually refer to **Section 9.0**, **DOUBLE-CHECKING** your routing and length calculations before cutting any wires and making connections. Give special attention to Turn Signal and Ignition Switch connections. These can be somewhat confusing.

- 6.4.1 Have all needed tools and connectors handy.
- 6.4.2 Select the correct size terminal for the wire and stud application.
- 6.4.3 Determine the correct wire length and cut the wire. Remember to allow enough slack in the harness and wires at places where movement could possibly occur, such as automobile body to frame, frame to engine, etc. **Double-check your calculations.**
- 6.4.4 Strip insulation away from wire. Strip only enough necessary for the type of terminal lug you are using.

Note: In the following step, make sure that the terminal is crimped with the proper die in the crimping tool. An improper crimp will NOT make a good connection.

- 6.4.5 Crimp the terminal onto the wire.

CAUTION: DO NOT OVER-CRIMP!

- 6.4.6 Connecting the harness throughout the groups is a redundant process. Make sure that each wire is FIRST properly routed and THEN attach. **DO NOT ATTACH FIRST THEN ROUTE AFTERWARD.**
- 6.4.7 When all wires are attached, tighten the mounts and ties to secure harness permanently.

6.5 Testing The System

- 6.5.1 Use a small (10 amp or less) battery charger to power up the vehicle for circuit testing. If there is a problem anywhere, the battery charger's low amperage and internal circuit breaker will provide circuit protection.

CAUTION: IF YOU HAVE NOT YET DISCONNECTED THE BATTERY FROM THE AUTOMOBILE, DO SO NOW! DO NOT CONNECT THE BATTERY CHARGER WITH THE BATTERY CONNECTED.

Connect the battery charger's NEGATIVE output to the automobile chassis or engine block and its POSITIVE output to the automobile's positive battery terminal.

- 6.5.2 INDIVIDUALLY turn on each light, ignition, wiper circuit, etc. and check for proper operation.

Note: The turn signals will not flash properly if you do not have both the front and rear bulbs installed and connected.

- 6.5.3 When all circuits check out THEN attach the battery cable to the battery for vehicle operation.

7 MOPAR - SPECIFIC CIRCUIT CONNECTIONS

7.1 Mopar Alternator. See Figure 9-1

Note: Your Alternator may not appear exactly as represented in **Figure 7-1**. The circuits are wired the same way, though.

7.1.1 Mopar uses one of two kinds of voltage regulators: An electronic regulator and a mechanical one. The electronic voltage regulator is represented in **Figure 7-1A**. It does not matter how the two terminals are connected, so long as they are BOTH connected. The mechanical regulator has terminals marked "F" (Field) and "I" (Ignition). In contrast to the electronic regulator, it DOES make a difference how the mechanical regulator is connected.

7.1.2 Connect ENGINE SECTION wire #914 (BLU) to the Alternator Field (F) terminal as shown in **Figure 7-1A**. Connect ENGINE SECTION wire #915 (BLK) to the Alternator Output lug (Bat).

CAUTION: IF USING AN ALTERNATOR WITH AN OUTPUT LARGER THAN 65 AMPS, YOU WILL ALSO NEED TO USE JUMPER WIRE #960 (RED), INCLUDED IN BOX. THE WIRE END WITH THE RING TERMINAL AND RUBBER BOOT WILL CONNECT TO THE ALTERNATOR OUTPUT LUG. ROUTE THE OTHER END TO THE STARTER. CUT THE WIRE AND CRIMP ON A RING TERMINAL. INSTALL ON SAME TERMINAL OF MAXI FUSE AS #916 RED. SEE FIGURE 7-1B.

7.1.3 Connect a 14-gauge wire from the Alternator terminal where wire #914 is connected to either of the ELECTRONIC Voltage Regulator terminals OR terminal (I) of the MECHANICAL Voltage Regulator. On existing Mopar harnesses, this would be a blue wire.

7.1.4 Connect a 14-gauge wire from the other Alternator Field terminal (as shown in **Figure 7-1**) to the second terminal of the ELECTRONIC Voltage Regulator OR terminal (F) of the MECHANICAL Voltage Regulator. On existing Mopar harnesses, this would be a green wire.

7.1.5 Finally, be sure BOTH the alternator and the voltage regulator itself are grounded.

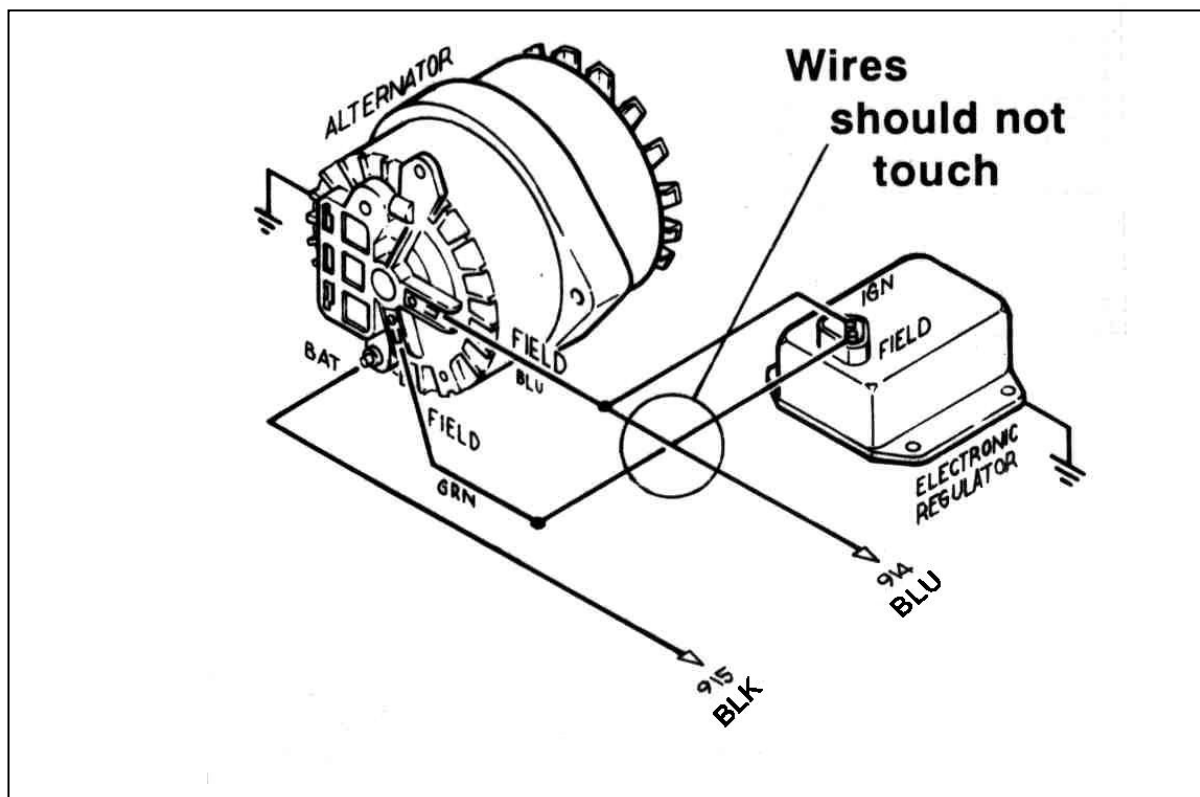

Figure 7-1A Mopar Alternator

7.2 Mopar Ignition (Start/Run) System. See Figure 7-2A

Note: If you are going to install an ammeter, see **Section 8.3** first.

7.2.1 Connect ENGINE SECTION (single) 10-gauge red wire #916 (with or without ammeter) to the MAXI fuse. Use remaining 10 ga. to connect to Starter Relay Battery Terminal. Retain excess wire.

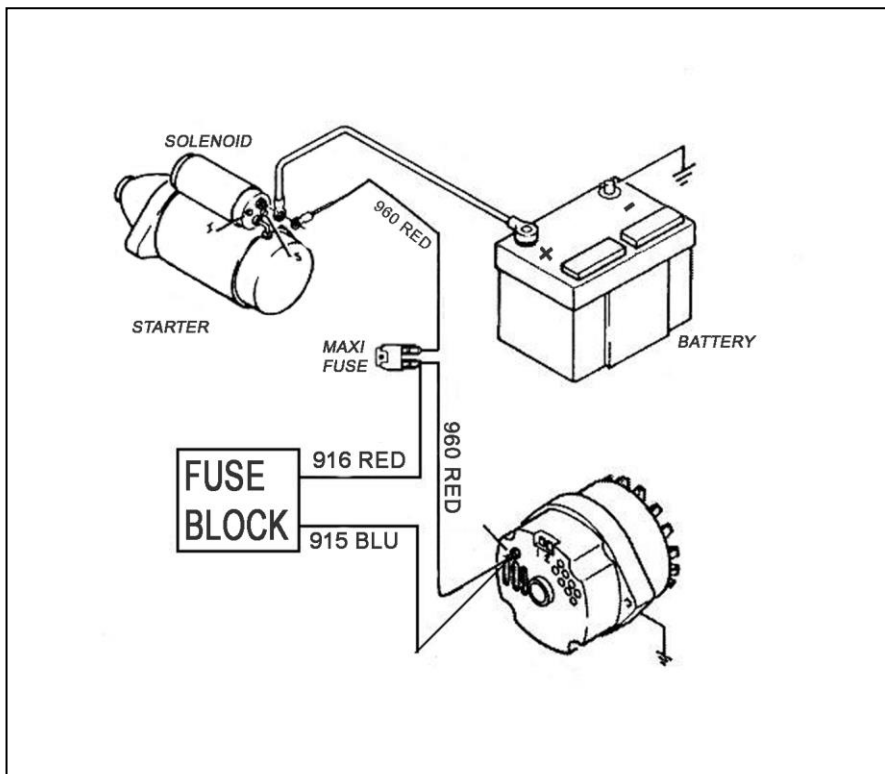

Figure 7-1B High Output Wire

- 7.2.2** With crimping tool, attach the Maxi Fuse onto remaining length of red 10-gauge wire. It serves as a fuse to protect the entire harness. **DO NOT OMIT IT!** Connect this wire from the Starter Motor Battery terminal, as shown in **Figure 7-2A**. **USE ONLY 10-GAUGE WIRE or LARGER.**
- 7.2.3** Connect ENGINE SECTION A wire #919 (YLW) to the Starter Relay Ignition (I) terminal.
- 7.2.4** Connect a 14-gauge wire from the Starter Relay Ground (G) terminal to the center terminal of the transmission mounted Neutral Safety Switch. Older Mopar neutral safety switches have only one terminal. On newer switches, the two outside terminals are for backup lights (see **Figure 7-2A**).
- 7.2.5** If the Neutral Safety Switch is mounted in the floor shifter, connect the Starter Relay Ground (G) terminal to chassis ground. Refer to **Paragraph 7.4.2** to wire the Neutral Safety Switch.
- 7.2.6** If you are using the Ballast Resistor, mount it away from other wiring or hoses. The ballast resistor gets very hot during operation. Connect ENGINE SECTION A wire #931 (BRN) to one end of the Ballast Resistor. Connect the other end of the ballast resistor to the Ignition Coil POSITIVE (+) terminal with 14-gauge wire (you may have enough BROWN wire left over to accomplish this). If you are not using a Ballast Resistor, connect wire #931 directly to the Ignition Coil B+ terminal. Wire #920 (BLU) will connect to the other side of the ballast resistor. **Figure 7-2A**
- 7.2.7** The Ignition Coil NEGATIVE (-) terminal is connected to the Distributor. Also connect ENGINE SECTION A wire #923 (GRY/BLK) to the Ignition Coil NEGATIVE (-) terminal. This is the tachometer source. If you are not using a tachometer, insulate and stow wire #923.

If using a Mopar Electronic Ignition, the Black/yellow wire from the module will also connect to the negative side of the coil.
- 7.2.8** Be sure the large, red battery cable is connected from the Battery to the Starter Motor Battery terminal (the same place the Maxi Fuse is connected).
- 7.2.9** If using a Mopar Dual ballast resistor, see **Figure 7-2B**.

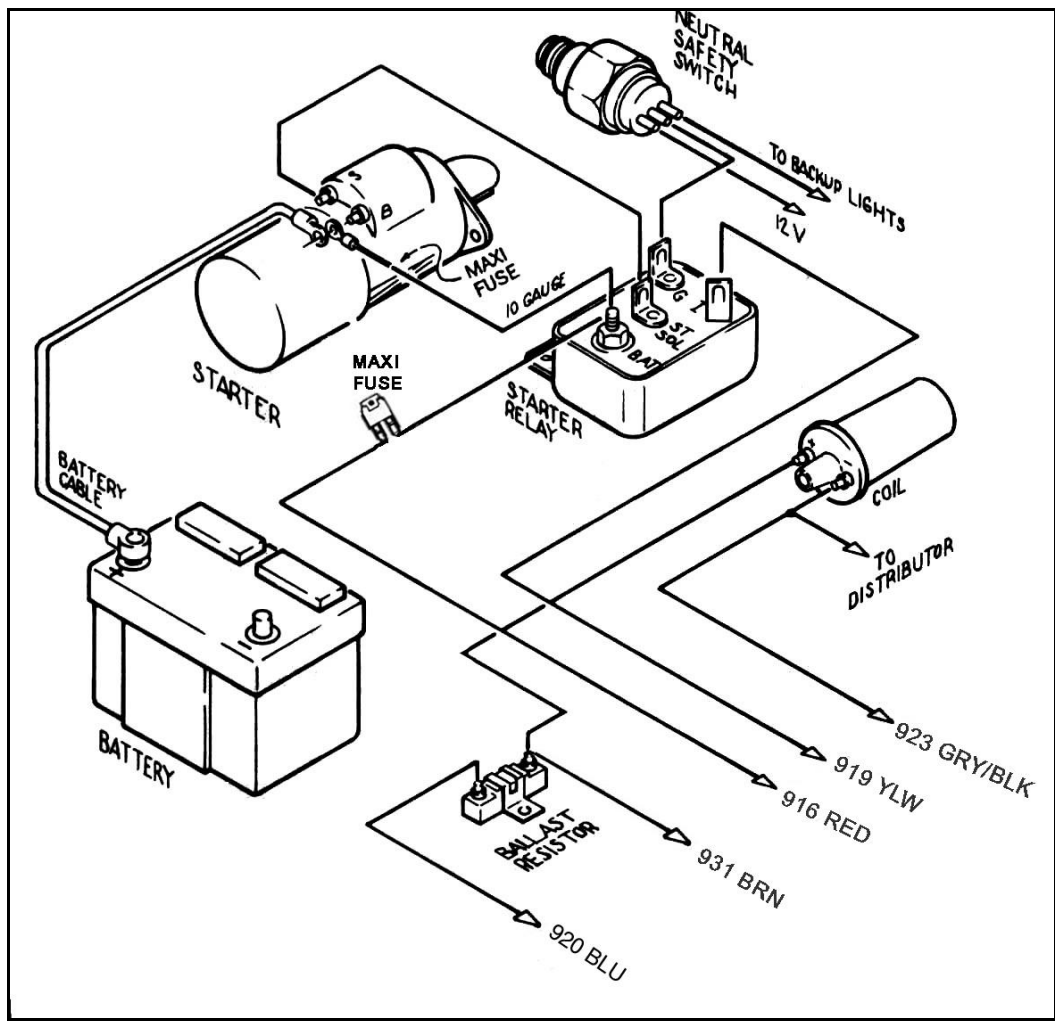

Figure 7-2A Mopar Ignition (Start/Run) System

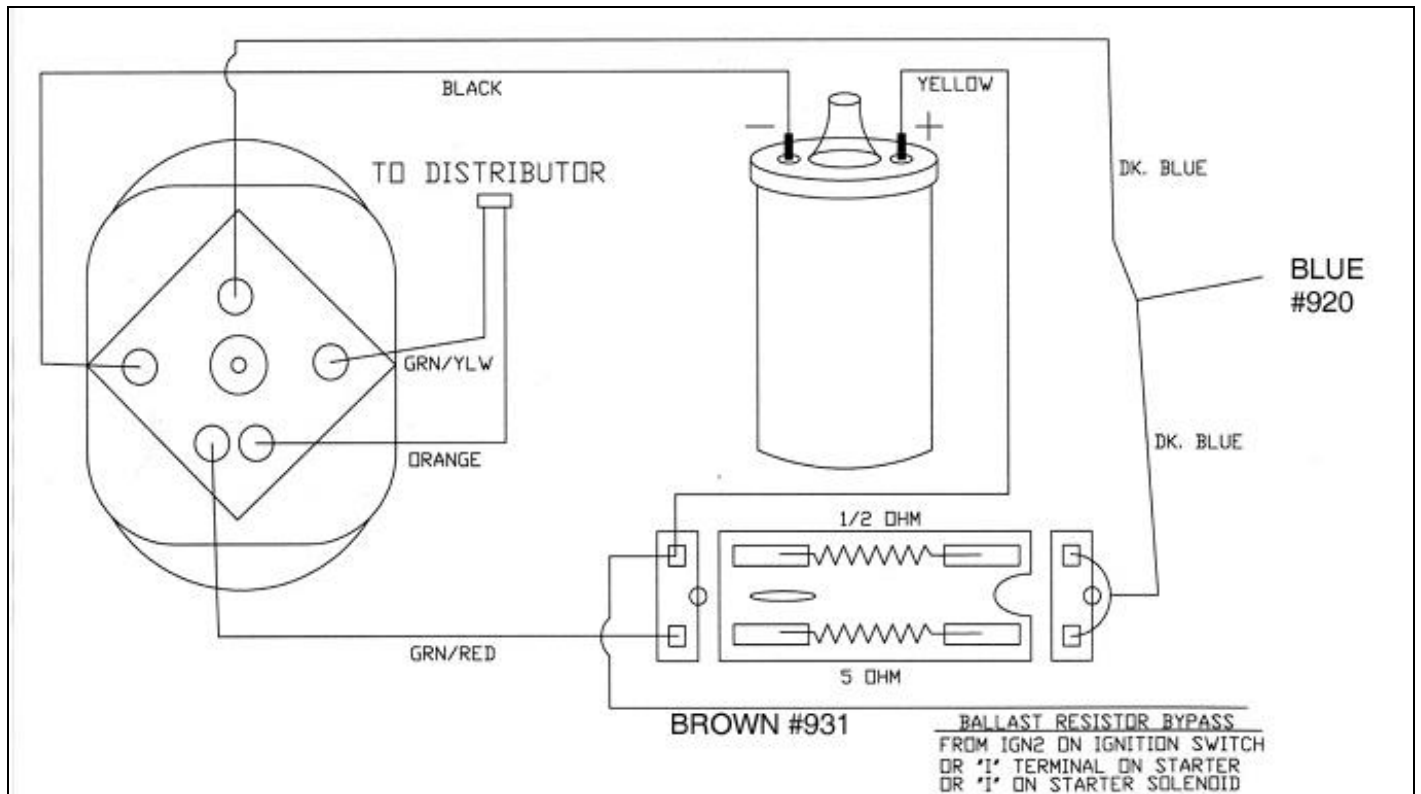

Figure 7-2B Mopar Electronic Ignition with Dual Ballast Resistor

7.3 Steering Column Wiring - Turn Signal Connections

Refer to **Table 7-1**. Check your existing wiring (by tracing the wire, if necessary) against the data given.

7.3.1 According to **Table 7-1**, connect the wires of the TURN SIGNAL SECTION using the supplied terminals (see **Figure 7.3**) to your automobile's existing Turn Signal Connector. Mopar wire color codes for a number of years are provided for reference. Mopar has not been uniform in assigning wire colors over the years; so you may find that the wire colors in your existing Mopar harness differ from those shown.

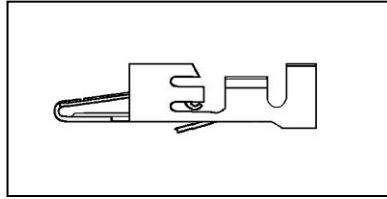

Figure 7.3 Turn Signal Connector Terminal

7.3.2 If there is any doubt, be on the safe side. Trace the wire(s) with an ohmmeter, circuit tester, or test light. DON'T GUESS!

Note: Disconnect one end of the wire you are tracing. If you leave it connected, there is a possibility of tracing it back through some other circuit and getting false results.

7.3.3 If your existing Turn Signal Connector requires a Horn Ground wire, install one. The TURN SIGNAL SECTION has no ground wire, nor does it support seat belt buzzers, or key alarms. If your using an aftermarket column which requires GM turn signal connectors, you'll need Painless part #30806.

7.4 Steering Column Wiring - Ignition Switch Connections

7.4.1 Connect the wires of the IGNITION SWITCH SECTION according to **Table 7-1**.

7.4.2 IGNITION SWITCH SECTION wire #919 (Ylw) is to be connected to a Neutral Safety Switch. However, Mopar switches are mounted in the transmission. The transmission-mounted neutral safety switch was wired at **Paragraph 7.2.4**. FOR SAFETY, PLEASE USE A NEUTRAL SAFETY SWITCH!

7.4.3 If the neutral safety switch is mounted on a floor shifter, see note 7 in wire connection index.

1970-74 WITHOUT TILT COLUMN			
TURN SIGNAL CONNECTOR			
Mopar Color	Designation	Painless Wire No.	Painless Color
Wht	Stop Light Switch	918	Wht
Tan	RF Turn Signal	925	Tan
Grn	LF Turn Signal	926	Lt.Grn
Brn	RR Turn Signal	948	Brn
Grn	LR Turn Signal	949	Grn
Blk	Hazard Flasher	951	Blk
Red	Turn Flasher	952	Red
Blk	Horn	963	Blk
IGNITION SWITCH CONNECTOR			
Ylw ¹	Ignition Start	919	Ylw
Brn	Ignition Coil	931	Brn
Blk	Accessory Fuse Panel	932	Blk
Blu	Ignition Switched Fuse Panel	933	Blu
Red	Battery B+	934	Red
NOTES:			
1. 12 gauge wire			

Table 7-1 Mopar Ignition and Turn Signal Wiring

8 ALL MAKES - SPECIFIC CIRCUIT CONNECTIONS

8.1 Generator Charging System. See Figure 8-1.

- 8.1.1 Connect Generator ARMATURE terminal (A) to Voltage Regulator terminal A. Connect Generator FIELD terminal (F) to Voltage Regulator terminal F. Use 14-gauge wire (color optional) for FIELD and 12-gauge wire for Armature.
- 8.1.2 Be sure both the generator and the voltage regulator are securely grounded. The voltage regulator may have a terminal for this purpose (labeled "G") or you may have to ground the regulator case.
- 8.1.3 Connect ENGINE SECTION wire #915 (BLK) to Voltage Regulator terminal B.
- 8.1.4 Insulate and stow ENGINE SECTION wire #914 (BLU).

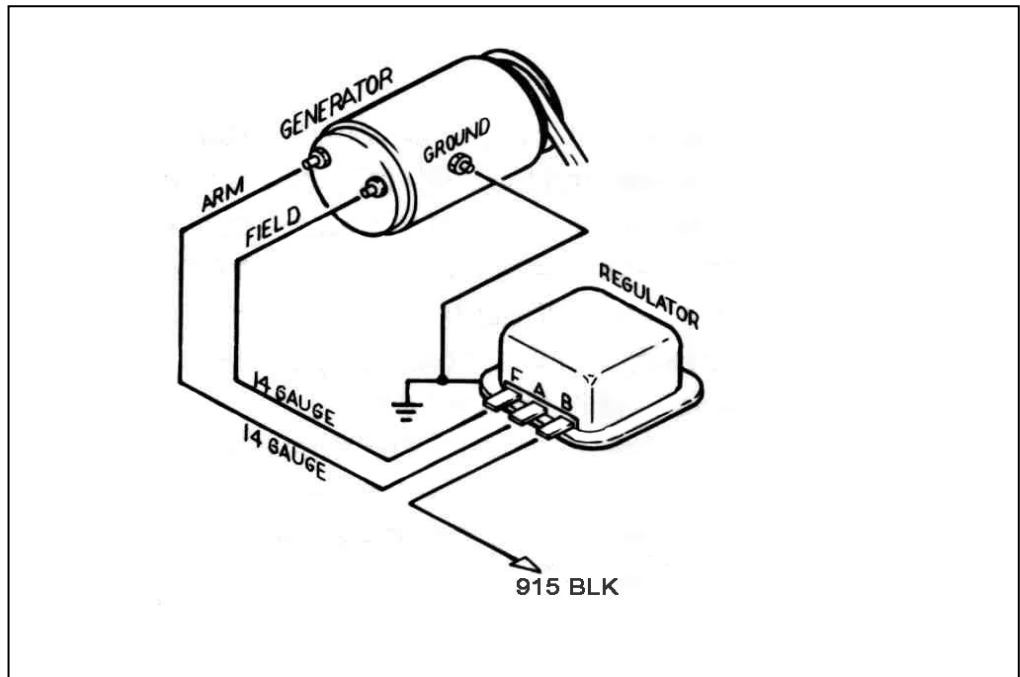

Figure 8-1 Generator Charging System

8.2 Generator to Alternator Conversion

- 8.2.1 You may be able to convert your generator charging system to use an alternator and external regulator without altering or re-routing existing wires.
- 8.2.2 Install the new alternator and replace the existing generator voltage regulator with the new, alternator compatible one.
- 8.2.3 Connect the existing wiring according to 7.1

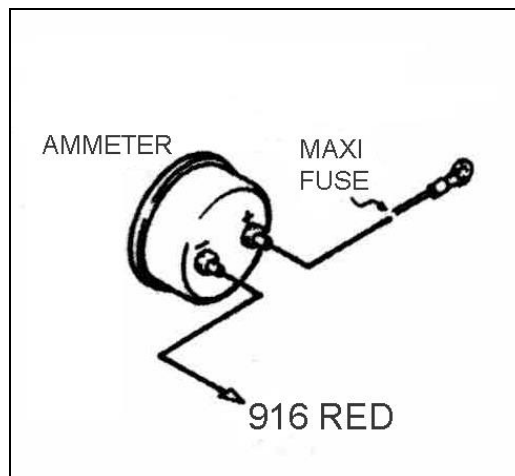

Figure 8-2 Ammeter & Maxi Fuse

8.3 Connecting an Ammeter and the Maxi Fuse. See Figure 8-2.

- 8.3.1** Most, but not all Ammeters must be inserted IN SERIES onto the ENGINE SECTION (single) 10-gauge wire #916 (red) that routes from the Fuse Panel to Maxi Fuse (**Section 7.2**).
- 8.3.2** The overall physical length of this circuit should be as short as possible (allow some slack, however). You may have to cut wire #916 and you may have to add some additional length of 10-gauge wire. USE ONLY 10-GAUGE WIRE OR LARGER.
- 8.3.3** Route wire #916 (from the Fuse Panel) and connect to the Ammeter NEGATIVE terminal. To complete the installation, follow ONE of the next three (3) paragraphs, as appropriate.
- 8.3.6** If you are using a Mopar starter with a starter relay, route the remainder of wire #916 from the Ammeter POSITIVE terminal to the Maxi Fuse terminal. Connect the other side of the Maxi Fuse to the Starter Solenoid Battery (B+) terminal.

CAUTION: BOTH AMMETER TERMINALS MUST ABSOLUTELY BE ISOLATED FROM GROUND. IF EITHER AMMETER TERMINAL COMES IN CONTACT WITH GROUND A HARNESS FIRE IS INEVITABLE. USE EXTREME CARE AND DILIGENCE IN CONNECTING AMMETERS.

CAUTION: BE SURE YOUR AMMETER'S CURRENT (AMPS) RATING EXCEEDS THE CURRENT OUTPUT OF YOUR ALTERNATOR. PERFECT PERFORMANCE PRODUCTS, LLC DOES NOT RECOMMEND USING ANY AMMETER RATED AT LESS THAN 65 AMPS. DO NOT USE AN AMMETER WITH ANY HIGH OUTPUT ALTERNATOR (MORE THAN 65 AMPS).

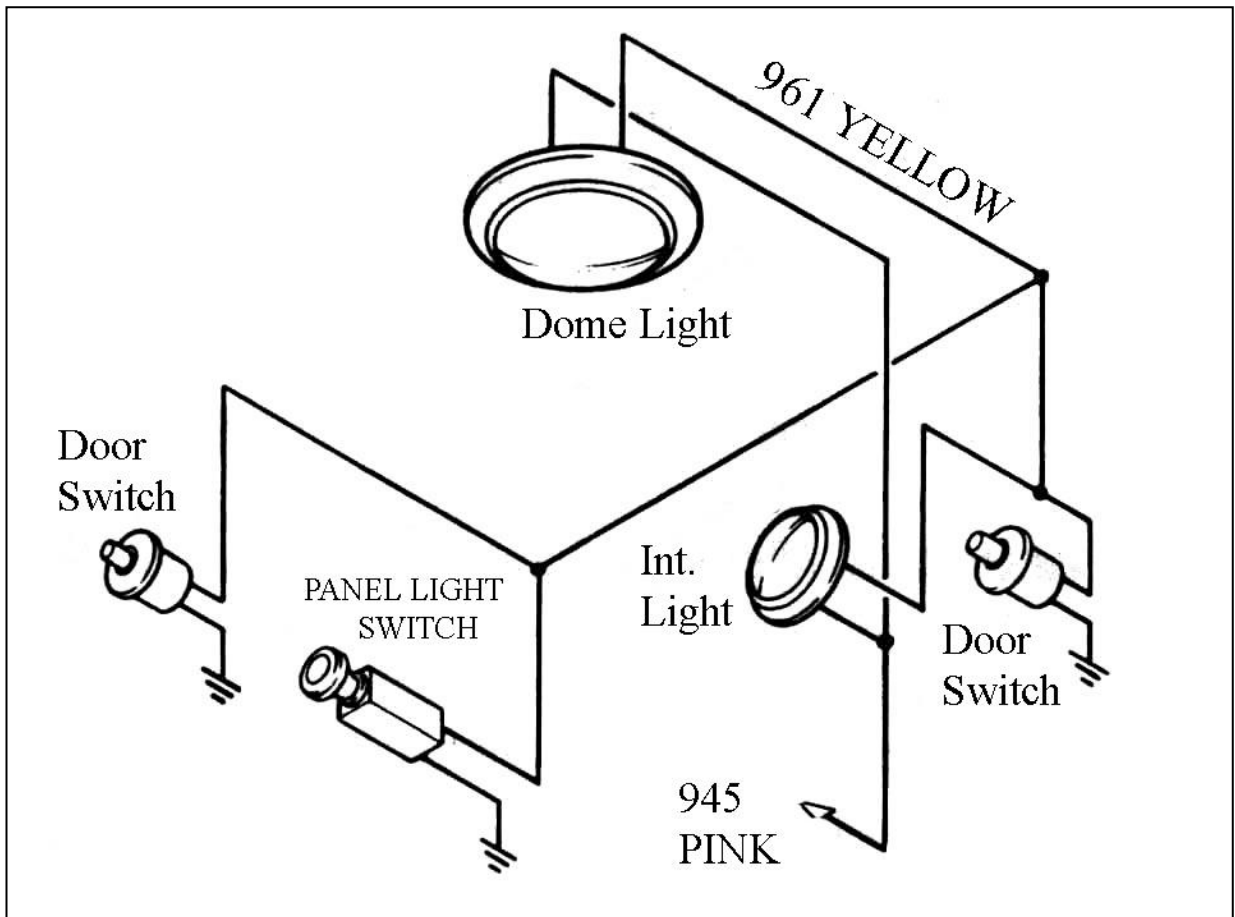

Figure 8-3 Interior Lighting

8.4 Interior Lighting. See Figure 8-3

- 8.4.1** Interior Lights are switched through the door switches and the dash panel light switch. These switches apply ground to the circuit. YOU WILL NEED TO SUPPLY THESE GROUND WIRES. 12V is continually present at the light bulbs. See **Figure 8-3**.
- 8.4.2** If possible leave your existing interior light wiring intact. The Painless harness supplies the 12V feed (B+) to the circuit via TAIL SECTION wire #945 (PNK) and a ground via TAIL SECTION/ PANEL LIGHT SECTION N wire #961 (YLW). For termination, see **8.10.3**.

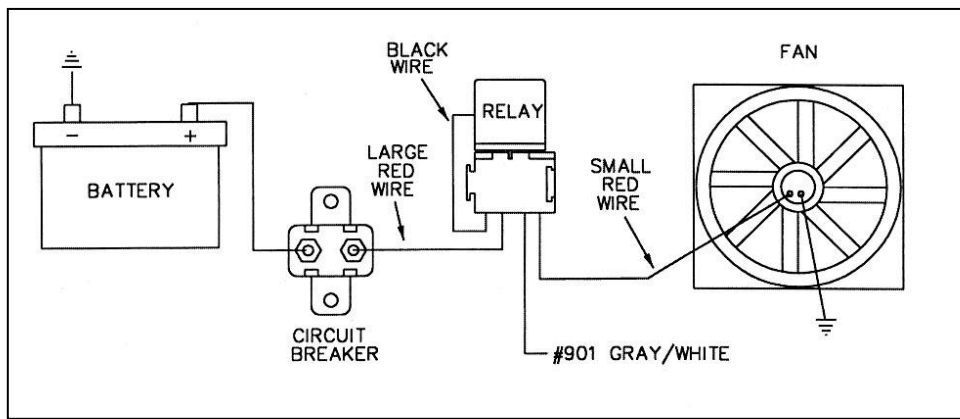

Figure 8-4A Typical Fan Relay Installation (**Painless Part #30101**)

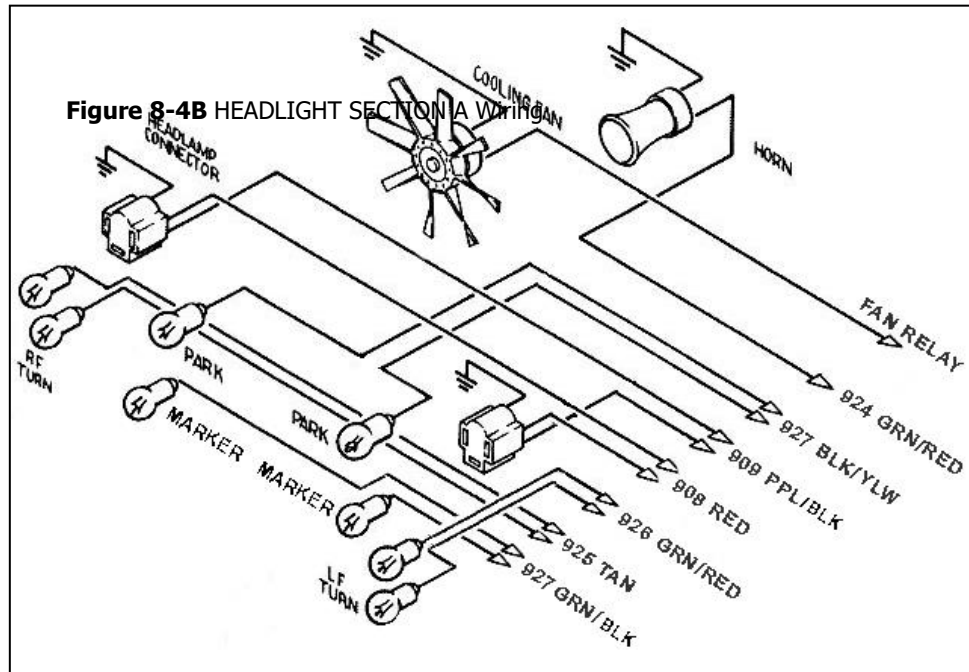
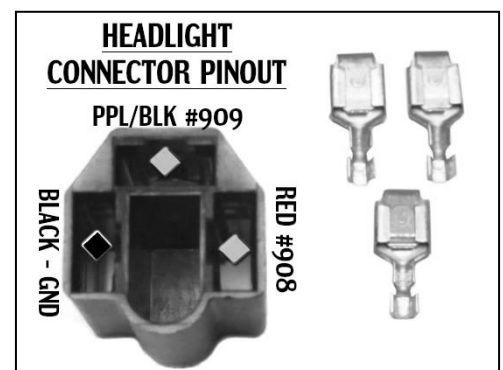

Figure 8-4B HEADLIGHT SECTION A WIRING

8.5 HEADLIGHT SECTION A. See Figure 8-4B.

- 8.5.1 Connect HEADLIGHT SECTION A wire #924 (GRN/RED) to the Horn's hot terminal. TURN SIGNAL SECTION wire #963 (BLK) was connected in the Turn Signal Connector section of these instructions. The Horn Relay is pre-wired into the Fuse Panel.
- 8.5.2 Route the HEADLIGHT SECTION A wires #908 (RED) and #909 (PPL/BLK) to BOTH Headlamps. Headlamp connectors, ground wires and terminals for the headlamps are provided in the parts kit. Ring terminals and self-tapping screws have also been provided for the ground connection.
- 8.5.3 Use the connector photo to the right for proper wire pinout. The connector is shown from the wire insertion side.
- 8.5.4 For models with separate high beam head lamps, extra head lamp connectors have been supplied. To make connections for separate high beam lamps, use the cutoff portion of the #908 (RED) wire to double the #908 wire at the first connector. Then, route the cutoff length of wire the high beam and connect using the extra terminals and connectors in the parts kit.
- 8.5.5 The left/driver side headlamp connector(s) can now be plugged into the headlamp(s) and the headlamp(s) can now be installed into the grille.



- 8.5.6 Connect the black wires of the Headlamp Connectors to Chassis Ground. You should have enough wire to accomplish this. You have been supplied with two small grommets should you need to pass these wires through a fender well. Don't forget to thread them onto the wires BEFORE you connect the wires.

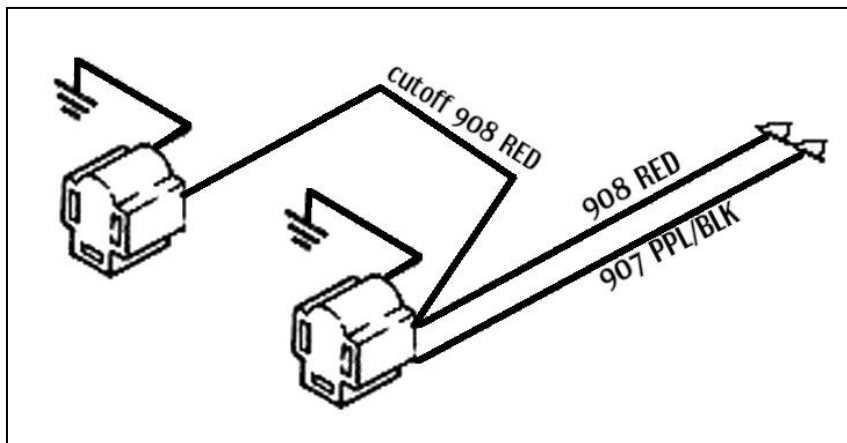

Figure 8.5A Dual Headlamp Connections

- 8.5.3 Connect HEADLIGHT SECTION A wires #927 (BLK/YLW) to ALL front Park Lights and wires# 927 (BLK/YLW) to both Marker Lights. Connect HEADLIGHT SECTION A wires #925 (TAN) to the RIGHT FRONT Turn Signal(s). Connect wires #926 (GRN/RED) to the LEFT FRONT Turn Signal(s). **Note:** Don't confuse Park Lights or Marker Lights with Turn Signals. For termination, see **8.10.3**

- 8.5.4 Connect HEADLIGHT SECTION A wire #901 (GRY/WHT) to the Electric Fan Relay. This wire is an activation wire for the relay, **NOT A POWER FEED**. The other end of wire #901 is in the ACCESSORY SECTION SWITCHES and should be connected to a electric fan switch in the dash. Connect 906 (GRY/WHT) from ACCESSORY SECTION B+ to the other side of the fan switch. **Figure 8-4A** shows a typical fan relay installation.

Note: The wire going to the fan in **Figure 8-4B** will be coming from the fan relay output terminal. Wire #901 (GRY/WHT) from the ACCESSORY SECTION SWITCHES is an activation wire for the fan relay.

NOTE: If you are using a thermostatic switch in the engine to control the ground for the fan relay, you will then connect the 901 (GRY/WHT) from ACCESSORY SECTION SWITCHES directly to the 906 (GRY/WHT) from ACCESSORY SECTION B+.

- 8.5.5 Connect the DIMMER SWITCH SECTION to your floor-mounted Dimmer Switch or column-mounted Dimmer Switch.

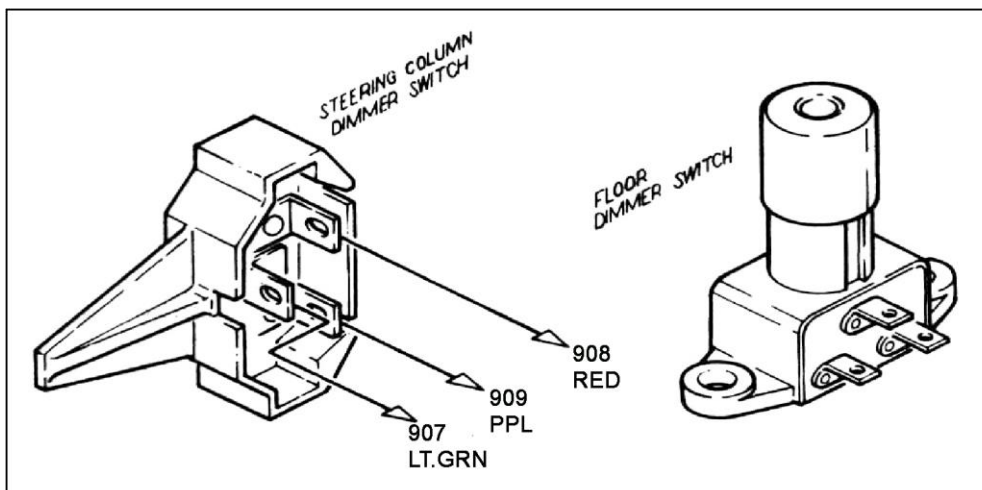

Figure 8-5B Dimmer Switches (Push Button Style – Painless Part #80150)

8.6 HEADLIGHT SECTION B, HAZARD SWITCH, PANEL LIGHT Wiring.

- 8.6.1 Connect the 5 wires of HEADLIGHT SECTION B, the 4 wires of the HAZARD SWITCH SECTION, the 3 wires of the PANEL LIGHT SECTION. You should trace out the wires of your existing harness and connect the new harness according to **Table 9-1**. A headlight switch connector and terminals have been provided; they are located in their own parts bag.

8.7 Instrument Panel Wiring

- 8.7.1 Connect the wires of the INSTRUMENT PANEL SECTION as indicated in **Table 9-1**. Insulate and stow any wires you do not use.
- 8.7.2 Connect a jumper from wire #935 (BLK) to all Gauges' power or "I" terminals. Connect a jumper from wire #930 (ORN) to all Gauges' Instrument Lighting terminals. Connect a jumper to all Gauges' Ground terminals and connect to Chassis Ground. *For termination, see 8.10.3*
- 8.5.1 Refer to the diagram on page 24 for the proper connection of the #991 (Blk), #992 (Ylw), and #993 (Ylw/Blk) wires

8.8 Brake Light Switch

- 8.8.2 Connect wires #917 (PNK) and #918 (WHT) to the Brake Light Switch wherever it may be mounted. These wires are in ENGINE SECTION A
- 8.8.3 The Third Brake Light wire is pre-connected on the Switch end. Connect TAIL SECTION wire #950 (ORN) to the Third Brake Light if applicable.

8.9 Tail Section Wiring

- 8.9.2 Connect the wires of the TAIL and TURN SIGNAL SECTIONS as indicated in **Table 9-1** with the exception of #918 (WHT), #948 (BRN), #949 (GRN) and #950 (ORN).
- 8.9.3 These 4 wires will be connected according to one of the diagrams shown in **BELOW**. Which diagram you will use depends on whether or not you have one bulb on each side of the vehicle that is for the brake/tail **and** Turn Signal Lights (this is referred to as integrated lights) **or** you have **more than one** bulb on each side **and** the Brake and Turn Signal Lights are hooked to different bulbs (referred to as separate Brake/Turn Lights).

Note A: *If you have Integrated Brake Lights you must use bulbs that have two (2) filaments in them such as in an 1157 bulb.*

Note B: *The three wires shown in these diagrams are connected to the "brighter" of the two filaments when using a two-filament bulb (the Tail Lights are usually connected to the "Dimmer" filament). The Tail Lights, License Plate Lights, Reverse Lights, etc. are not shown on the diagrams for clarity.*

Note C: *In the separate Brake Light diagram the arrangement shown is only one of several ways to wire a vehicle. The important thing is that the Brake and Turn Signal Lights use completely separate bulbs.*

Note D: *The white wire (#918) in the Turn Signal section will not be connected to the turn switch when using separate turn lights and brake lights. See figure 8-7B*

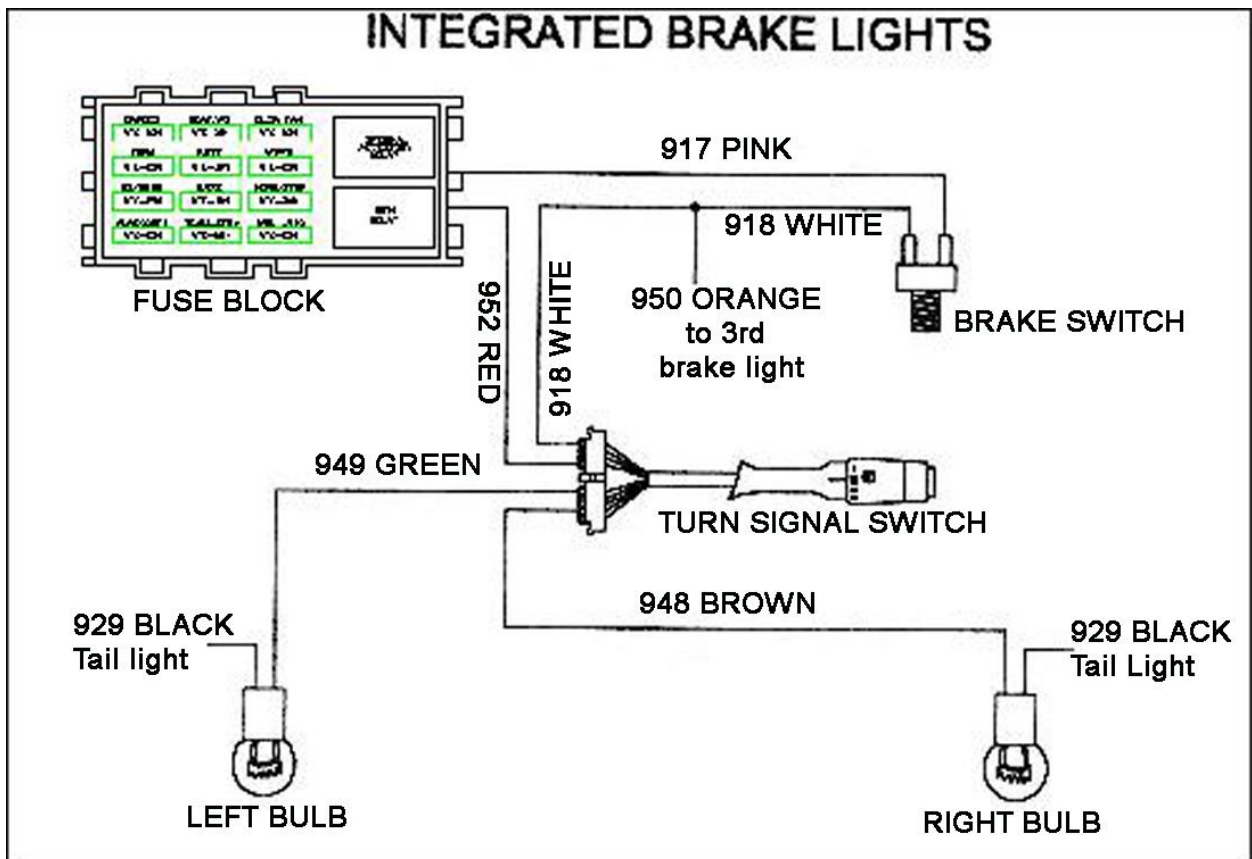

Figure 8-7A Integrated Brake Lights

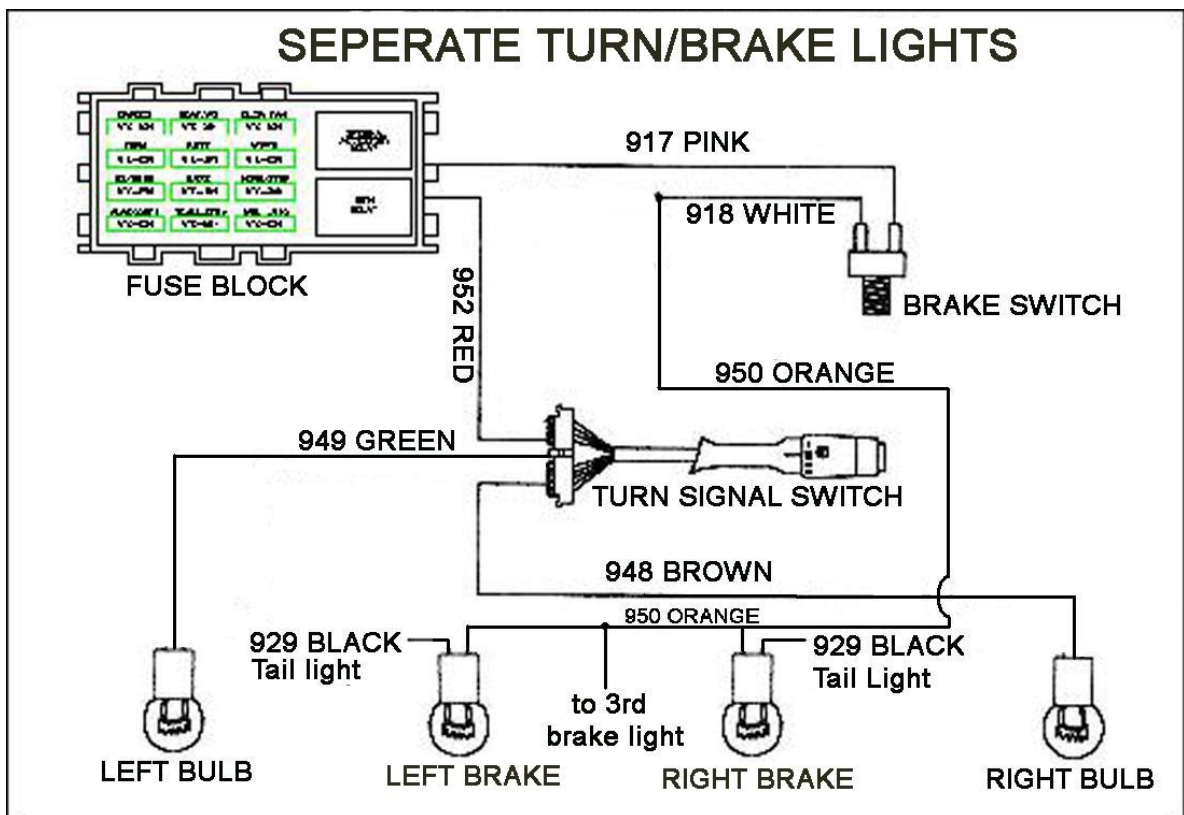

Figure 8-7B Separate Turn/Brake Lights

8.10 Helpful Hints for Tail Section Wiring

- 8.10.1** When you have Integrated Brake Lights on your vehicle the Turn Signal switch acts as a brain to control when the Lights in the rear are on constantly (braking) or flashing (turning) or a combination of both. **The Turn Signal switch you use must be built to do this! If you are using a steering column out of a salvage yard that was originally in a vehicle that had separate Brake Lights then the switch will not work for Integrated Brake Lights.**
- 8.10.2** Almost all light bulbs get the ground they need through the socket housing. If you mount your socket housing into anything other than a grounded metal part then you will need to provide a separate ground wire.
- 8.10.3** This kit has a bag containing 30 Mopar lamp socket terminals. These terminals fit all lamp socket housings through out the entire vehicle. Follow these instructions for proper installation and refer to **Figure 8.10B**:
- 1:** Insert the wire into the correct location of the lamp housing. *Housing must be installed before the terminal is crimped. These terminals are pull to seat.*
 - 2:** Slide the factory spring over the wire. You must re-use your factory spring.
 - 3:** Place the terminal over the wire by prying up the center "prong" and sliding the wire under, *see the arrow in Figure 8.10A*, then crimp. If the wire is not inserted under the prong, a proper crimp will be impossible to achieve.

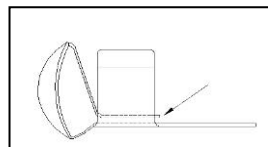

Figure 8.10A Lamp Socket Terminal

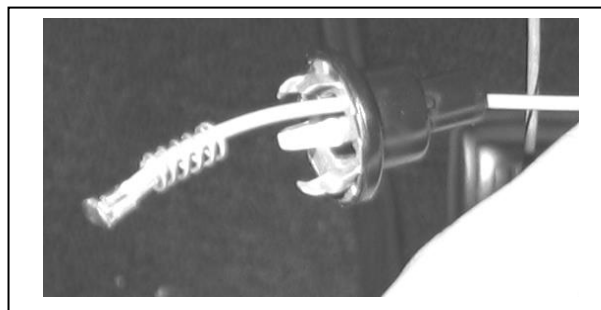

Figure 8.10B Lamp Socket Assembly

9.0 WIRE CONNECTION INDEX

9.1 Wire Connection Index

In each section, connect the wire, as identified by its wire color, to the appropriate item in the CONNECT TO column. Pay close attention to the **Notes** in this section, as identified by a small, raised number such as the one at the end of this sentence. ❶

Table 9-1 is divided into sections that correspond to the sections of your wire harness. (ACCESSORY SECTION B+, DIMMER SWITCH SECTION, etc.). The index is divided vertically into six columns. COLOR, GAUGE, NUMBER, CONNECT TO, ORIGIN, and SECTION OF ORIGIN.

The columns labeled ORIGIN and SECTION OF ORIGIN are for your reference ONLY. The items in these columns tell you where each wire originates (ORIGIN) and from which section (SECTION OF ORIGIN) of the harness.

The column labeled NO. contains a 900-series number that is used to identify various wires in the wiring diagrams that are a part of these instructions.

Many (but not all) of the wire numbers occur TWICE in this index. That is because you will be connecting BOTH ENDS of many of the particular wire segments. However, some wire segments are pre-connected at one end. For instance, all wires originating from the fuse panel and certain other wires such as those originating from the horn relay, the dimmer switch, and the instrument panel section. **These pre-connected wires are identified by an asterisk (*) in the ORIGIN column.**

NOTES:

1. 2-color wires: 2nd color (stripe) may not be intense color. Observe two-color wires closely.
2. This section consists of only one large (10 gauge) wire.
3. From fuse panel to brake switch.
4. This wire needs to go from the headlight switch to the instrument panel lights.
5. This wire is power for the portion of the headlight switch that goes out to the headlights and front parking lights.
6. This wire is power for the portion of the headlight switch that goes out to the instrument panel lights and the tail lights. **NOTE: This wire is only used if your headlight switch has two power input terminals.**
7. If a floor shifter is being used, utilize this extra length to route the 919 Yellow to the neutral safety switch on the shifter or transmission and then to the starter solenoid. If not using a floor shifter, cut 919 Yellow to length needed for starter solenoid and discard extra length.
8. If a floor shifter is being used, utilize this extra length to route the 930 Orange to the gear select Indicator light on the console. If not using a floor shifter, cut 930 Orange to length needed to reach the gear select indicator light.

Color	Ga.	No.	Connect to	Wire Starting Point	Section of Starting Point
ACCESSORY SECTION SWITCHES					
Gry/Wht ¹	18	901	Cooling Fan Switch	Fan Relay	Headlight Section A
Blk/Wht ¹	14	902	AC/Heat Switch	A/C Compressor	Engine Section A
ACCESSORY SECTION B+					
Blk/Wht ¹	14	904	AC/Heat Switch B+	Fuse Panel*	Fuse Panel
Pnk	16	905	Wiper Switch B+	Fuse Panel*	Fuse Panel
Gry/Wht ¹	18	906	Cooling Fan Switch B+	Fuse Panel*	Fuse Panel
DIMMER SWITCH SECTION					
Lt.Grn	14	907	Dimmer Switch	Headlight Switch	Headlight Section B
Red	14	908	Dimmer Switch	High Beam	Headlight Section A
Pur	14	909	Dimmer Switch	Low Beam	Headlight Section A
ENGINE SECTION					
Blu	14	914	Alternator Exciter	Fuse Panel*	Fuse Panel
Blk	10	915	Alternator B+	Fuse Panel*	Fuse Panel
Blk/Wht ¹	14	902	A/C Compressor	A/C Central Switch	Accy. Section Switches
ENGINE SECTION (SINGLE WIRE)					
Red ²	10	916	Battery Positive or Starter Solenoid (Large Terminal)	Fuse Panel*	Fuse Panel
ENGINE SECTION A					
Pnk ³	14	917	Brake Switch B+	Fuse Panel*	Fuse Panel
Wht	16	918	Brake Switch	Turn Signal Switch	Turn Signal Section
Ylw ⁷	12	919	Start Solenoid ("S" Terminal)	Ignition Switch Start	Ignition Switch Section
Pur	18	921	Temperature Sending Unit	Temperature Gauge	Instrument Panel Section
Gry	18	922	Oil Pressure Sending Unit	Oil Pressure Gauge	Instrument Panel Section
Gry/Blk ¹	18	923	Tachometer Source	Tachometer	Instrument Panel Section
Red	18	954	Electric Choke	Fuse Panel*	Fuse Panel
Blu	14	920	Ballast Resistor/Coil +	Fuse Panel*	Fuse Panel
HEADLIGHT SECTION A					
Grn/Red ¹	14	924	Horn B+	Horn Relay*	Fuse Panel
Tan	18	925	Right Front Turn Signal(s)	Turn Signal Switch	Turn Signal Section
Lt.Grn	18	926	Left Front Turn Signal(s)	Turn Signal Switch	Turn Signal Section
Blk/Ylw ¹	18	927	Park Lights	Headlight Switch	Headlight Switch Section
Blk/Ylw ¹	16	927	Marker Lights	Headlight Switch	Headlight Switch Section
Red	16	908	High Beam	Dimmer Switch	Dimmer Switch Section
Pur	16	909	Low Beam	Dimmer Switch	Dimmer Switch Section
Gry/Wht ¹	18	901	Fan Relay	Fan Switch	Accy. Section Switches
HEADLIGHT SECTION B					
Blk/Wht ^{1,5}	12	928	Headlight Switch B+	Fuse Panel*	Fuse Panel
Lt.Grn	14	907	Headlight Switch	Dimmer Switch	Dimmer Switch Section
Blk	14	929	Headlight Switch	Tail Lights	Tail Section
Blk/Ylw ¹	18	927	Headlight Switch	Park Lights	Headlight Section A
Pnk	14	959	Headlight Switch B+	Fuse Panel*	Fuse Panel
IGNITION SECTION					
Blu	12	933	Ign. Switch Ignition	Fuse Panel*	Fuse Panel
Red	10	934	Ign. Switch B+	Fuse Panel*	Fuse Panel
Blk	12	932	Accy B+	Fuse Panel*	Fuse Panel
Brn	14	931	Coil B+	Fuse Panel*	Fuse Panel
Ylw	12	919	Start Solenoid ("S" Terminal)	Start Solenoid	Engine Section A
Org ⁸	16	930	Gear Select Indicator	Panel Light Switch	Panel Light section
Pur	16	956	Reverse Lights	Reverse Lights	Tail Section
Wht	16	958	Back Up Switch (B+)	Fuse Panel*	Fuse Panel

Color	Ga.	No.	Connect to	Wire Starting Point	Section of Starting Point
INSTRUMENT PANEL SECTION					
Blk	18	935	Voltmeter Source & Gauges B+	Fuse Panel*	Fuse Panel
Red	18	936	High Beam Indicator	Dimmer Switch*	Dimmer Switch Section
Lt.Grn	18	937	Left Turn Indicator	Left Front Turn Signal	Turn Signal Section
Tan	18	938	Right Turn Indicator	Right Front Turn Sig.	Turn Signal Section
Orn	18	930	Instrument Panel Lighting	Panel Light Switch	Panel Light section
Blu	18	939	Fuel Gauge	Fuel Sending Unit	Tail Section
Pur	18	921	Temperature Gauge	Temp. Sending Unit	Engine Section A
Gry	18	922	Oil Pressure Gauge	Oil Pres. Sending Unit	Engine Section A
Gry/Blk ¹	18	923	Tachometer	Tachometer Source	Engine Section A
Blk	18	991	Accessory Relay Ground	Fuse Panel*	Fuse Panel
Ylw	14	992	Accessory Relay Output	Fuse Panel*	Fuse Panel
Ylw/Blk ¹	14	993	Accessory Relay Activation	Fuse Panel*	Fuse Panel
RADIO SECTION					
Red	18	940	Radio B+ Unswitched (Constant)	Fuse Panel*	Fuse Panel
Orn	18	941	Radio B+ Switched	Fuse Panel*	Fuse Panel
TAIL SECTION					
Pnk	18	945	Dome Lights B+	Fuse Panel*	Fuse Panel
Brn	14	948	Right Rear Turn Signal	Turn Signal Switch	Turn Signal Section
Grn	14	949	Left Rear Turn Signal	Turn Signal Switch	Turn Signal Section
Blu	18	939	Fuel Sending Unit	Fuel Gauge	Instrument Panel Section
Blk	14	929	Tail Lights	Headlight Switch	Headlight Section B
Orn	18	950	Third Brake Light	Turn Signal Switch*	Turn Signal Section
Blk	16	929	Marker Lights	Headlight Switch	Headlight Section B
Blk	16	962	License plate light	Headlight Switch	Headlight Section B
Pur	16	956	Reverse Lights	Backup Switch	Ignition Section
TURN SIGNAL SECTION					
Red	14	952	Turn Signal Switch Flasher B+	Turn Flasher Relay*	Fuse Panel
Blk	18	963	Horn Switch	Horn Relay*	Fuse Panel
Brn	14	948	Turn Signal Switch	Right Rear Turn Signal	Tail Section
Grn	14	949	Turn Signal Switch	Left Rear Turn Signal	Tail Section
Tan	18	925	Turn Signal Switch	Right Front Turn Signal	Headlight Section A
Wht	16	918	Turn Signal Switch	Brake Switch	Engine Section A
Lt.Grn	18	926	Turn Signal Switch	Left Front Turn Signal	Headlight Section A
PANEL LIGHT SECTION					
Tan	16	930	Panel Light Switch	Instrument Lights	Instrument Cluster
Yel	18	961	Panel Light Switch	Dome Light	Tail Section
Blk	16	929	Panel Light Switch	Tail lights	Tail section
HAZARD SWITCH SECTION					
Lt. Grn	16	926	Hazard Switch	Left Front Turn Signal	Turn Signal Section
Tan	16	925	Hazard Switch	Right Front Turn Sig.	Turn Signal Section
Blk	16	951	Hazard Switch (B+)	Emer. Flasher Relay*	Fuse Panel
Wht	16	918	Hazard Switch	Brake Switch	Engine Section A

Table 9-1 Wire Connection Index, 2 of 2

INSTRUMENT PANEL SECTION WIRING

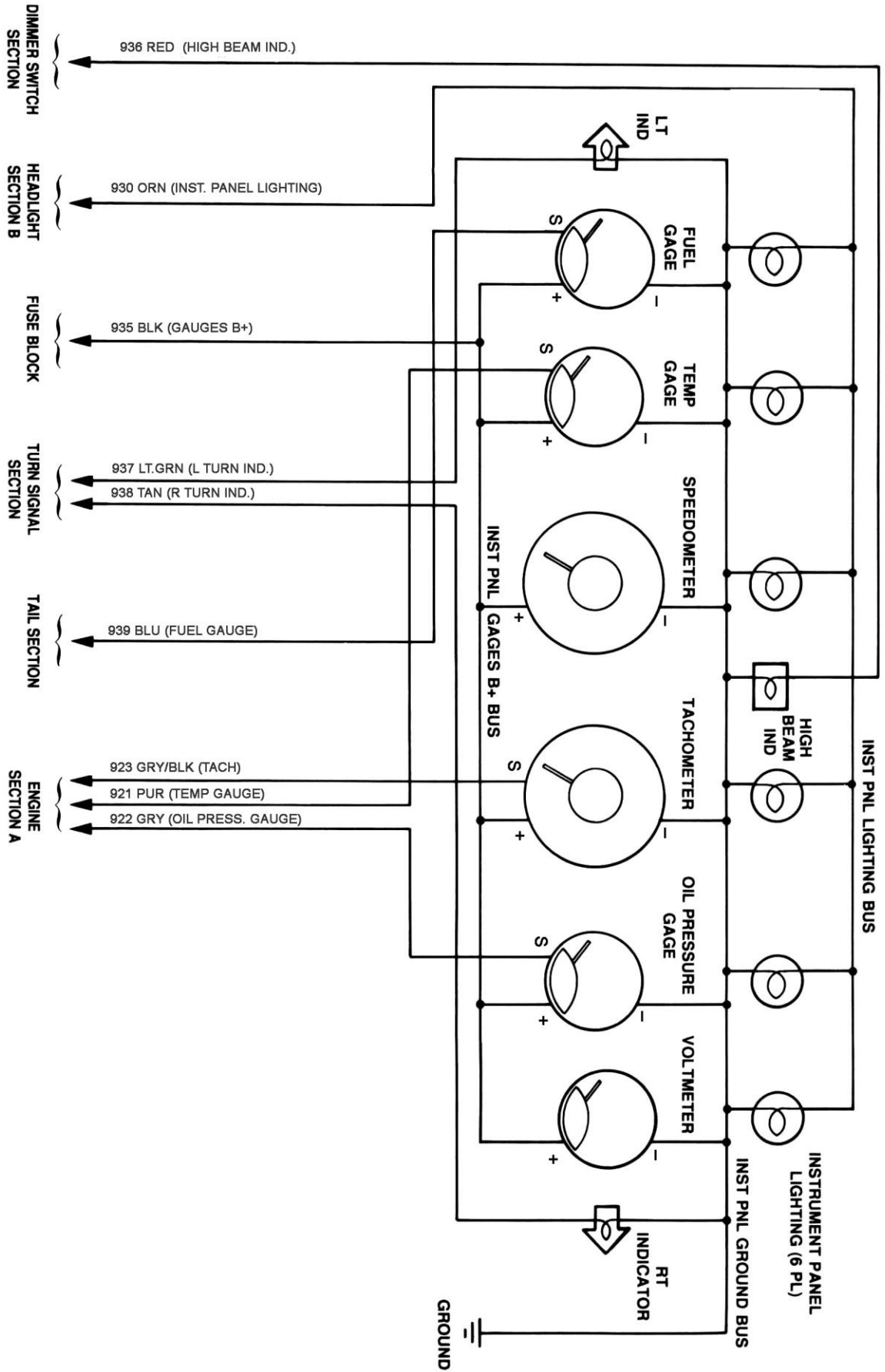

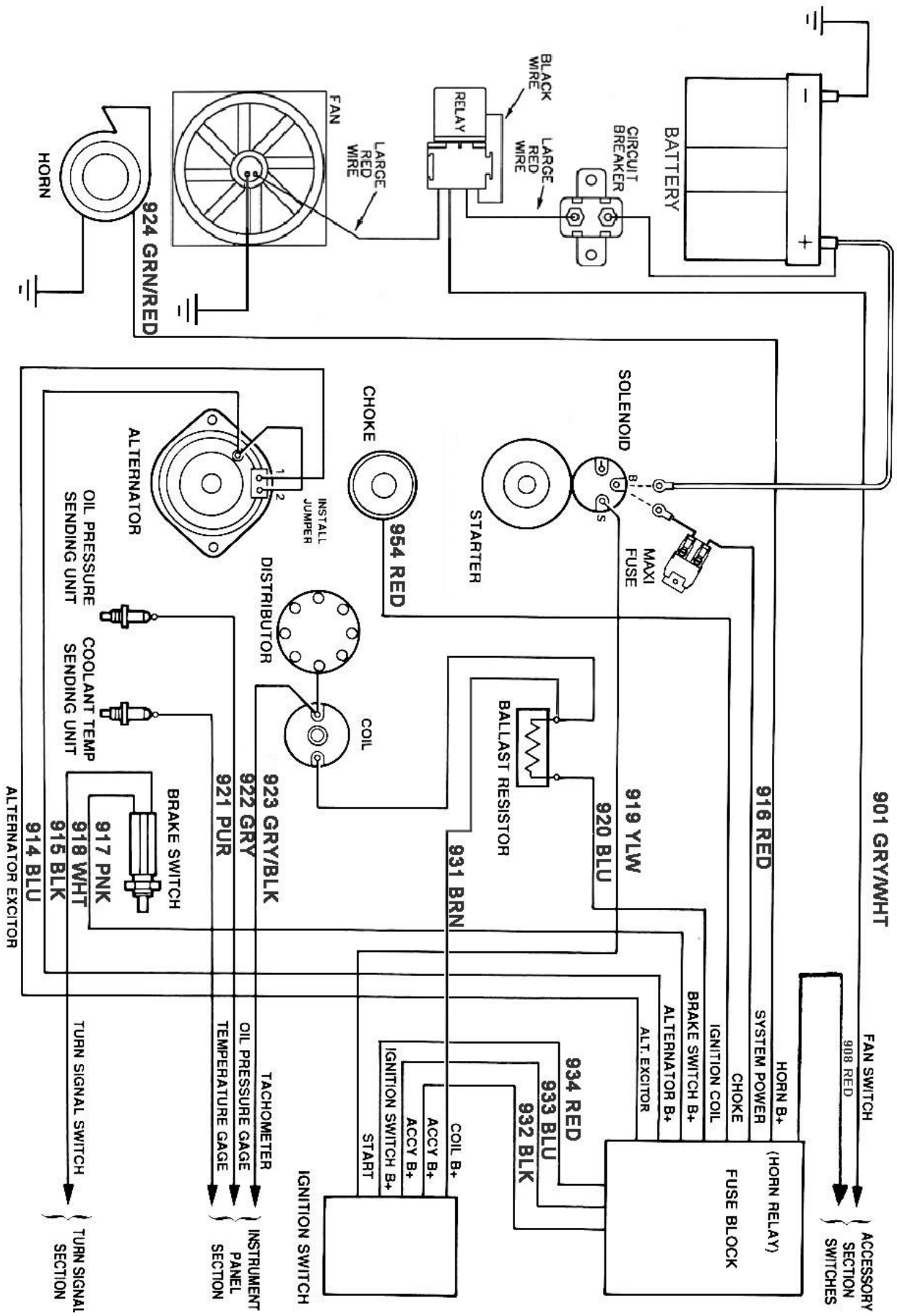

ENGINE WIRING

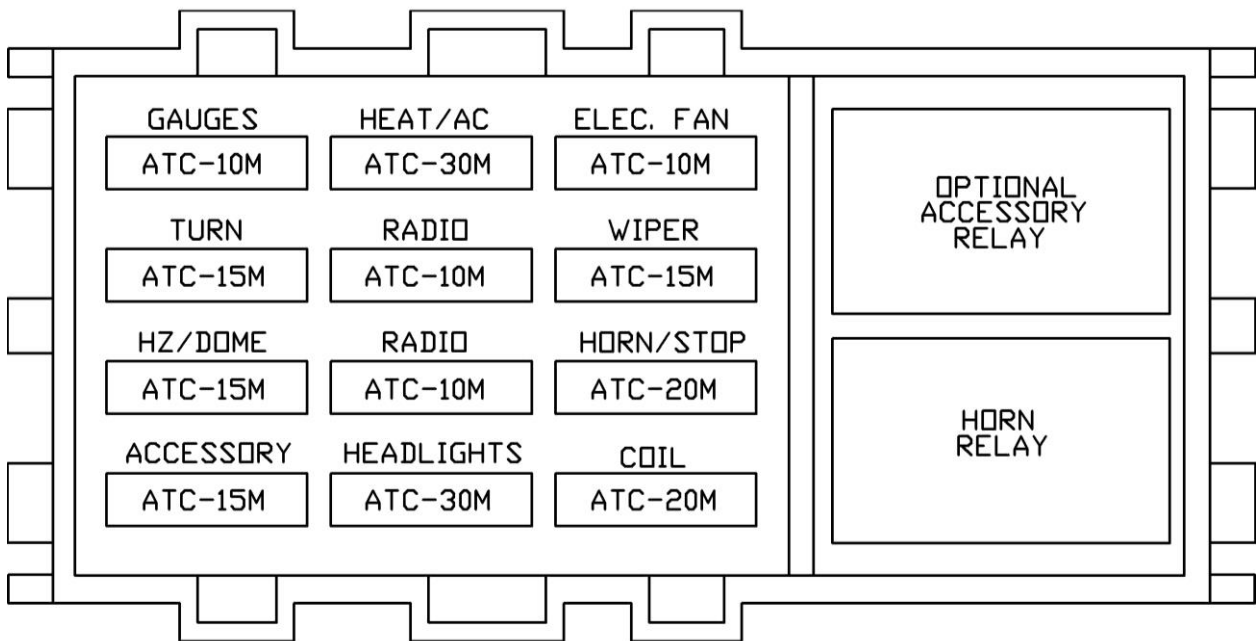

Accessory Relay- The connection of the #993 will determine if the relay can be activated at any time, battery power, or only when the key is in the "ON" position, Ign. Power. **DO NOT** wire the #991 directly to ground **AND** the #993 to a battery power source, this will cause a draw that will drain the battery.

ACCESSORY RELAY WIRES

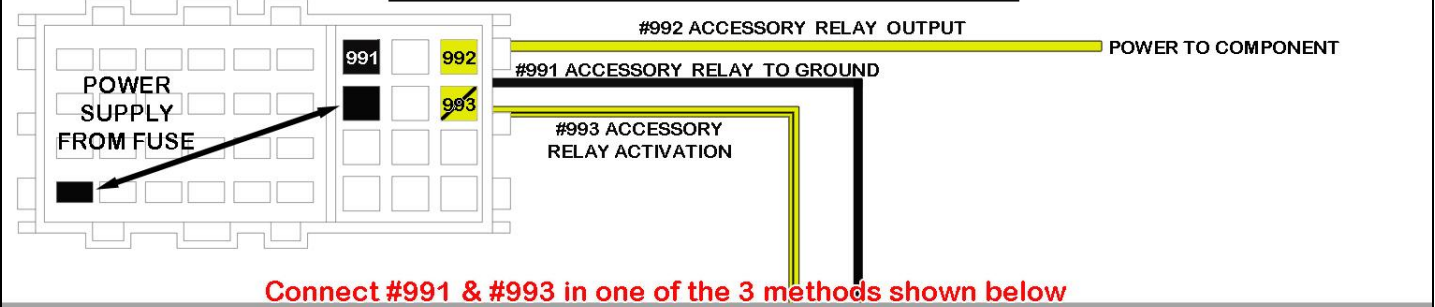

Connect #991 & #993 in one of the 3 methods shown below

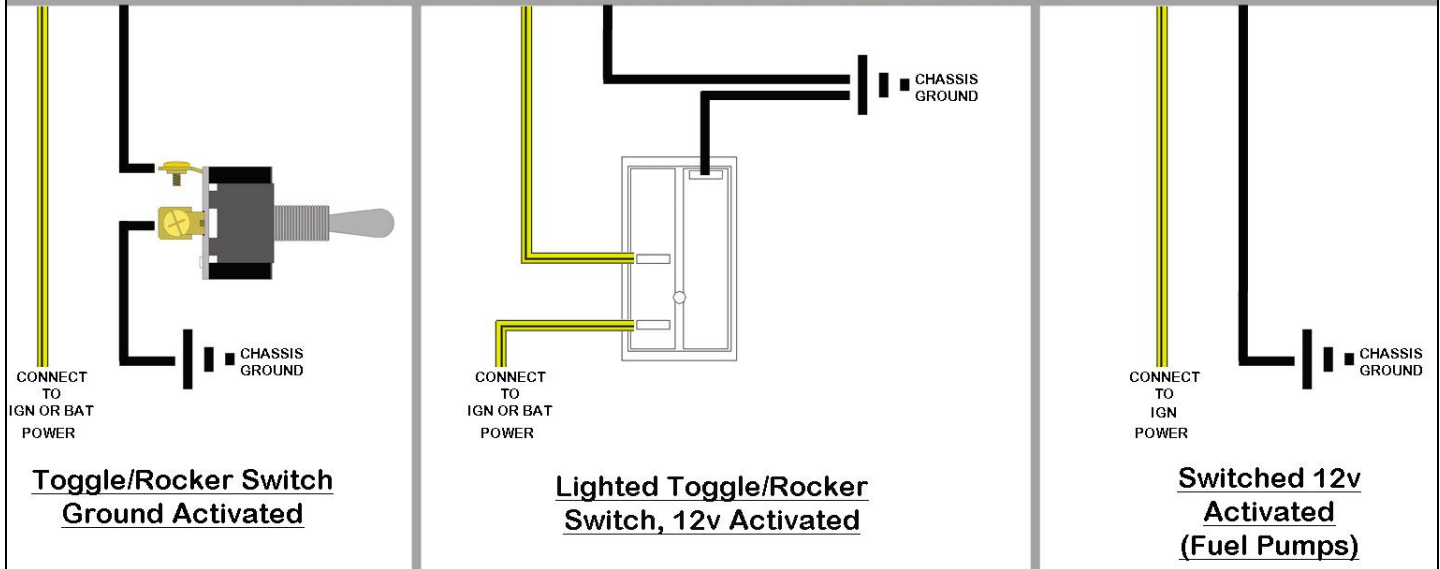

Painless Performance Products, LLC

Limited Warranty and Return Policy

Chassis harnesses, fuel injection harnesses, and Trail Rocker units are covered under a lifetime warranty.

All other products manufactured and/or sold by Painless Performance are warranted to the original purchaser to be free from defects in material and workmanship under normal use. Painless Performance will repair or replace defective products without charge during the first 12 months from the purchase date. No products will be considered for warranty without a copy of the purchase receipt showing the sellers name, address, and date of purchase. You must return the product to the dealer you purchased it from to initiate warranty procedures.