



2501 Ludelle Street
Fort Worth, Texas 76105
817-244-6212 phone
817-244-4024 fax
800-423-9696 Tech

E-Mail: painless@painlessperformance.com
Web: www.painlessperformance.com

30116

DUAL ACTIVATION / DUAL FAN RELAY KIT WITH 195° ON 185° OFF THERMOSTAT INSTALLATION INSTRUCTIONS

This electric fan relay kit will operate a dual fan setup, not to exceed 30 amps each. The relays will activate the electric fans if the thermostat reaches 195°F or if the A/C compressor clutch is engaged.

Additional instructions are provided for those with fuel injected vehicles equipped with an ECM that has cooling fan activation capabilities.

1. Mount the relays under the hood in a convenient location as close to the fans as possible. Use the 1/2" self tapping hex screws to mount the relay bases.
2. The 10 gauge black wire with the ring terminal preinstalled, printed "TO CHASSIS GROUND", will need to be connected to a ground source. Make sure the area you mount this provides a clean ground.

For those using a ground signal from an engine control module (ECM) to activate the fans, see the instructions on the following page on what to do with the "TEMP SWITCH" wires. It will be up to you, the installer, to determine if your ECM has these capabilities. It will also be the installer's duties to determine if their ECM has a single or dual (HI / LOW) activation and which pins of the ECM control cooling fan activation. Furthermore, if you are using a factory ECM that has an input from the A/C compressor, you may not need the compressor wire provided in this kit as your ECM will activate your fans when the ECM sees the compressor signal. If you are using an ECM to activate the fans, skip steps 3-4 and step 5 if your fuel injection harness has an A/C compressor wire going to the ECM. Instructions for your activation connection can be found on the next page.

3. Install the thermostatic switch, the brass temperature switch provided with this kit, into a water jacket in the head or intake manifold; a 1/2"NPT adapter has been included.
4. Route the 2 black wires labeled "TEMP SWITCH" to the installed thermostatic switch. These will be 18 gauge wires, printed "GROUND TO TEMP SWITCH" and "FAN ON SIGNAL-TEMP SWITCH TO RELAY". The "FAN ON..." wire will provide a ground signal to activate the 2 fan relays.

Cut these wires to length and strip 1/4" of insulation from both wires. Crimp the female spade connectors on to each of these wires. Push the spade connectors onto each of the male spades on the switch. It does not matter which wire goes where.

5. Route the 18 gauge Black wire, printed “A/C COMPRESSOR (12V TO RELAY)” to the A/C compressor clutch. Use a splice provided with this kit to connect this wire to the 12 Volt power wire that activates the A/C compressor clutch. When 12v is applied to the compressor, this wire will activate the A/C relay on this kit. The A/C relay then sends a ground signal to both fan relays which will in turn, activate the fan relays.
6. Use two self tapping hex head screws to mount the supplied MIDI fuse holder as close as possible to whichever power source (battery or large terminal on the starter solenoid) you are using to provide power to the fans. Remove the nuts and washers and install the 70 amp fuse included with the kit.
7. Route the 10 gauge red wire, printed “MIDI FUSE (BATTERY POWER)”, to one side of the fuse. Cut to length and install using one of the yellow ring terminals. Take the remaining length of red wire you cut and connect the opposite side of the fuse to the battery source.
8. Route the 2 groups of 12 gauge wires labeled “Fan #1/Low” and “Fan #2/High” from the relay to the electric fan motors. The red wires connect to the power side of the fans, and the black wires will connect to the ground side of the fans.

The connectors provided with the kit fit the popular General Motors LT1/LS1 dual fan assembly. The terminals for this connector require the wire to be passed through the connector, strip ¼” of insulation and then crimp the terminal onto the wire. Once crimped, pull the wire and terminal down into the connector.



ECM ACTIVATION-“TEMP SWITCH” WIRES

1. Locate the 18 gauge wire printed “GROUND TO TEMP SWITCH”. This wire will go back to a splice with 4 other black wires; this is the ground splice for the relay kit. This ground wire to the temp SWITCH is not needed; it can be cut at the splice, or rolled up and stowed away.
2. The other black wire in the “Temp SWITCH” group, the wire printed “FAN ON SIGNAL-TEMP SWITCH TO RELAY” will go back to a splice at the relays with a green wire and a blue wire. If you only have a single activation wire from your ECM, this black wire will need to connect to this single ground activation wire coming from your ECM; see **Figure 1**.

If you have 2 wires, High and Low activation, coming from your ECM, this splice will need to be cut to separate the blue and green wires. Using the splices provided, connect the low speed wire from your ECM to the Green wire going to the relay, and the high speed wire from your ECM to the blue wire going to the relay. This will activate each fan individually according to the High and Low commands coming from the ECM; see **Figure 2**.

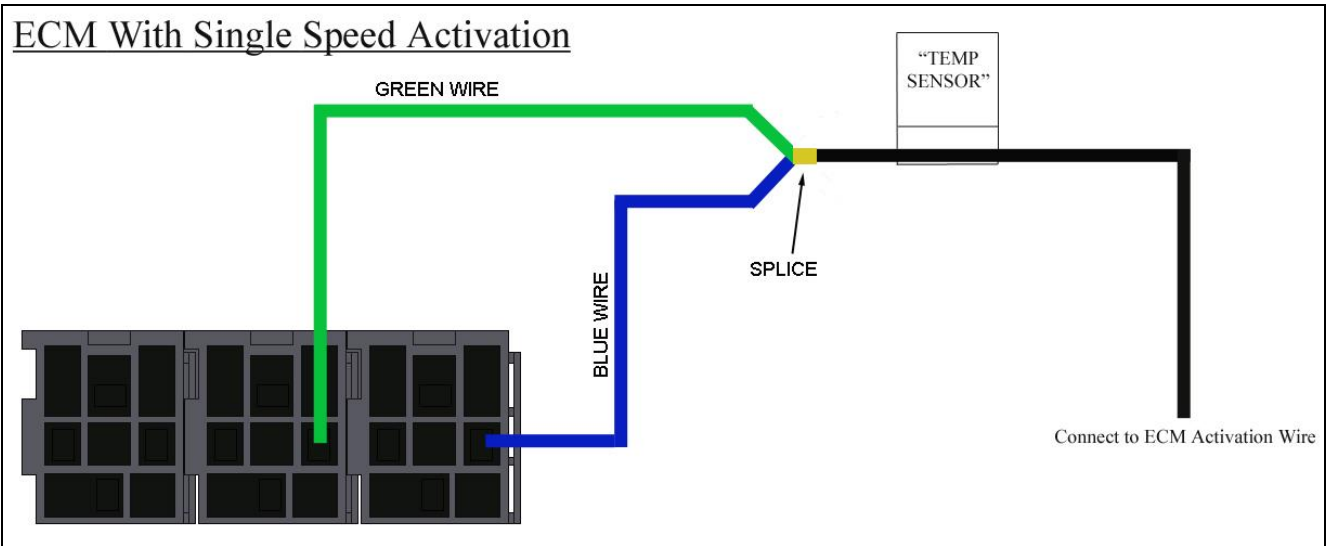

Figure 1

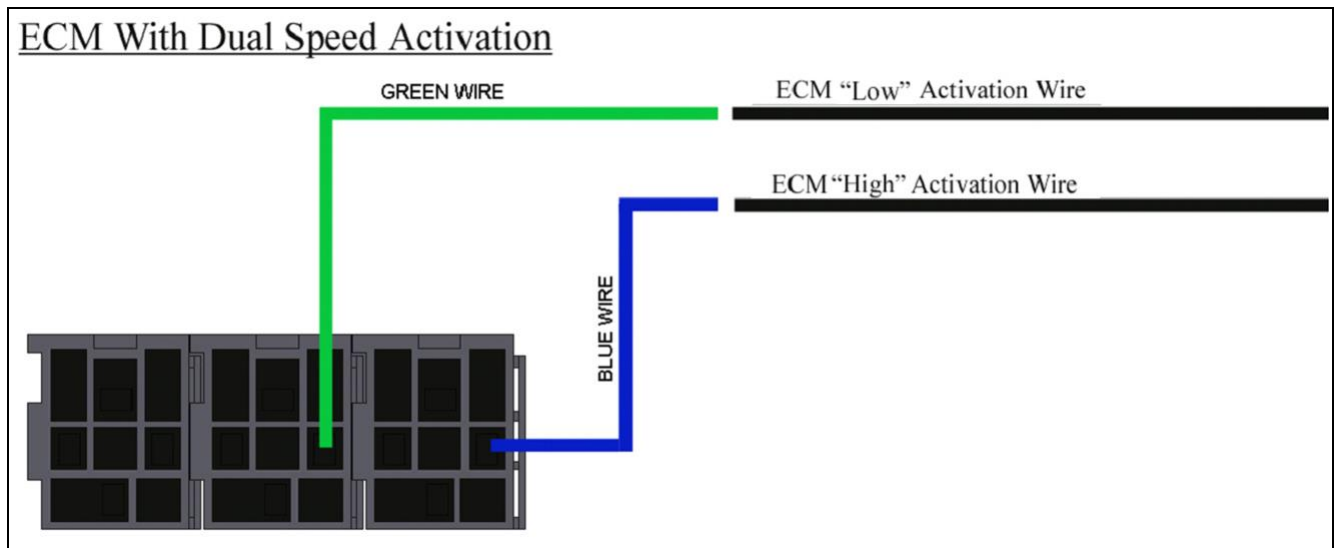

Figure 2

A full color schematic of this relay kit can be found on the reverse side of this page.

Painless Performance Limited Warranty and Return Policy

Chassis harnesses and fuel injection harnesses are covered under a lifetime warranty. All other products manufactured and/or sold by Painless Performance are warranted to the original purchaser to be free from defects in material and workmanship under normal use. Painless Performance will repair or replace defective products without charge during the first 12 months from the purchase date. No products will be considered for warranty without a copy of the purchase receipt showing the sellers name, address and date of purchase. You must return the product to the dealer you purchased it from to initiate warranty procedures

