



2501 Ludelle Street
Fort Worth, Texas 76105
817-244-6212 phone
817-244-4024 fax
800-423-9696 Tech

E-Mail: painless@painlessperformance.com
Web: www.painlessperformance.com

30353

1988-1991 SUBURBAN LIGHT SOCKET KITS

This kit contains light sockets for front and rear marker lights, front turn signal/park lights, rear turn-brake/tail lights, and reverse lights. Descriptions for these kits are based on headlight designation due to the fact that the front turn signal sockets are different based on the headlight configuration. **Headlight connection is not supported by this kit.** This kit was designed to work with any of our Classic Customizable, Classic-Plus 20205, and Pro Series harnesses which all include headlight connections. The instruction manual for each of these kits will go into more detail on the specific connections to these sockets.

Splices and heat shrink have been provided to make all power connections.

Ring terminals and heat shrink have been provided for ground connections. Smaller #8 ring terminals and self-tapping screws are for the front turn signal sockets, larger $\frac{3}{8}$ " ring terminals are for the rear sockets and will utilize the factory ground screw.

When connecting the rear grounds, there will be 3 sockets that connect to the tail light. Install all 3 ground wires into a $\frac{3}{8}$ " ring terminal, and then connect to the factory grounding screw.

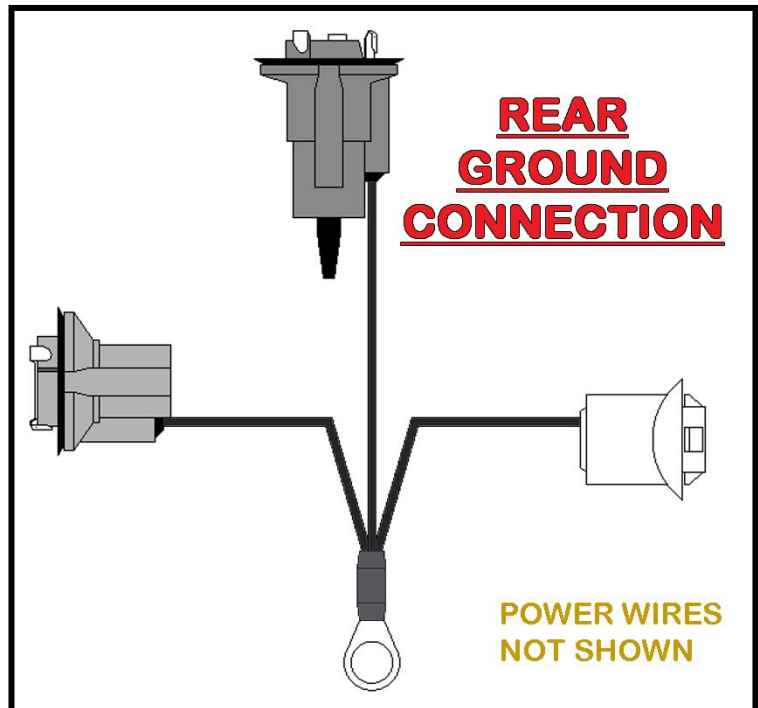

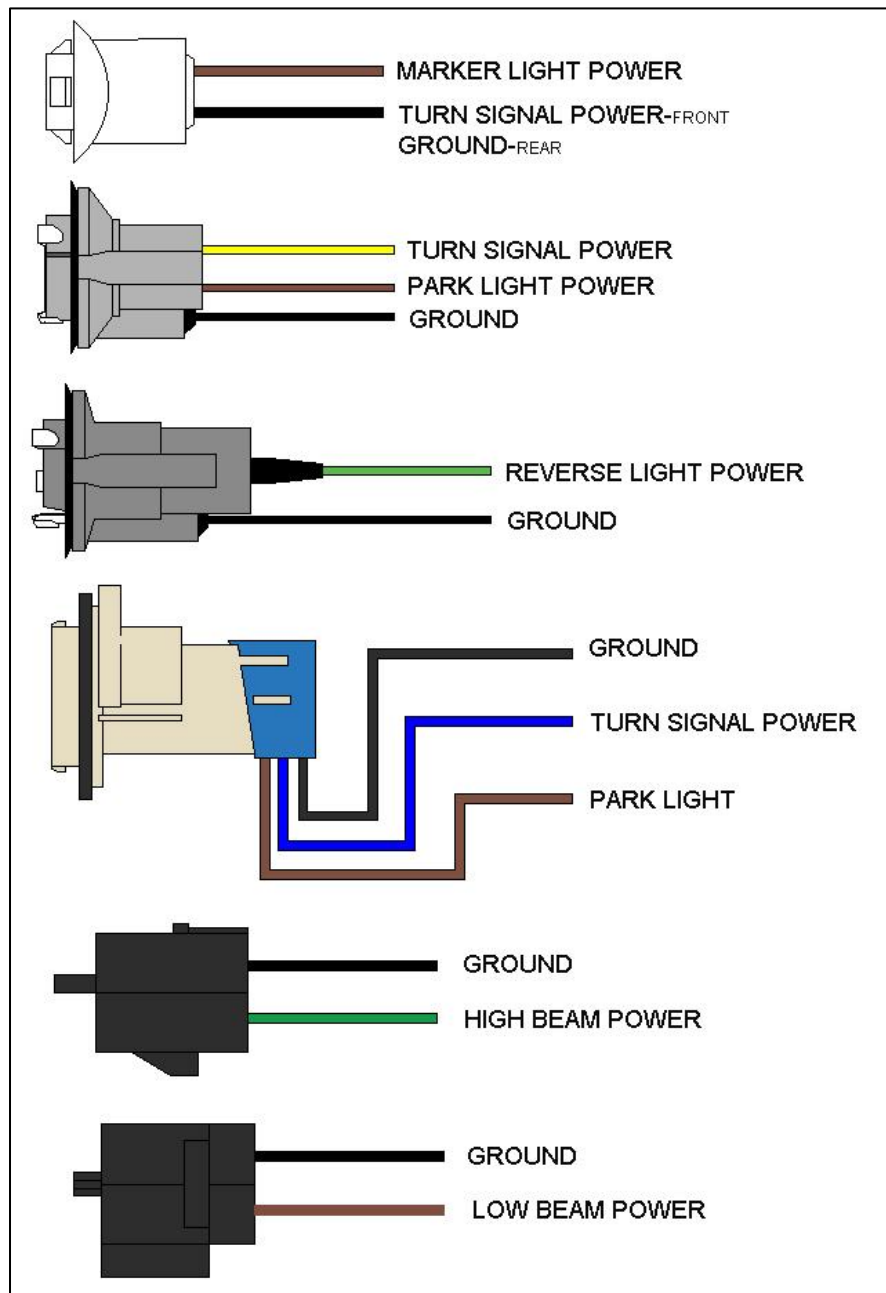

Painless Performance Products, LLC
Limited Warranty and Return Policy

Chassis harnesses, fuel injection harnesses, and Trail Rocker units are covered under a lifetime warranty.

All other products manufactured and/or sold by Painless Performance are warranted to the original purchaser to be free from defects in material and workmanship under normal use. Painless Performance will repair or replace defective products without charge during the first 12 months from the purchase date. No products will be considered for warranty without a copy of the purchase receipt showing the sellers name, address, and date of purchase. You must return the product to the dealer you purchased it from to initiate warranty procedures.