



2501 Ludelle Street
Fort Worth, Texas 76105
817-244-6898 phone
817-244-4024 fax
800-423-9696 orders

E-Mail: painless@painlessperformance.com
WebSite: <http://www.painlessperformance.com>

Installation Instructions

50432

1987-97 Mustang Carbon Fiber Switch Panel

The 50432 switch panel is designed to be mounted in the ashtray location using the screw and bracket provided.

The large red wire, that has been spliced several times, is included in the kit to provide power to all the switches. The spliced black wire is included to provide a ground to all the switches.

Individual wires with terminals on one end are the wires to be routed from the switch to the device being controlled. The terminal end is for the switch and once the wire has been routed, the extra length may be cut off and then terminated.

Remove the ashtray from the center console. Connect all the wires to the back of the switches as shown. Route the wires thru the ashtray opening in the console and out to the under dash area. Take the mounting bracket and place it in the ashtray opening and pull it up into place. The cut out on each end of the bracket fits around the tabs on each side of the bottom of the console. The bracket should fit snug and stay in place while you lower the switch panel into position and secure it using the supplied screw. Take the loose end of the wires and route out to the particular devices, cut, terminate and connect them.

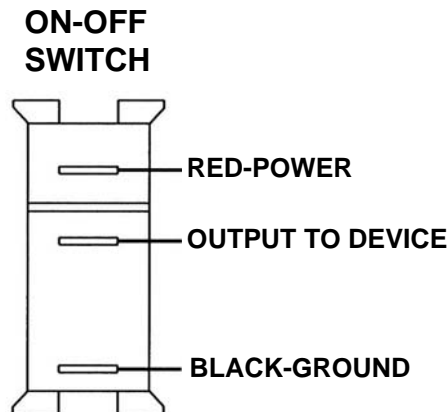

Painless Performance Limited Warranty and Return Policy

Chassis harnesses and fuel injection harnesses are covered under a lifetime warranty.

All other products manufactured and/or sold by Painless Performance are warranted to the original purchaser to be free from defects in material and workmanship under normal use. Painless Performance will repair or replace defective products without charge during the first 12 months from the purchase date. No products will be considered for warranty without a copy of the purchase receipt showing the sellers name, address and date of purchase. You must return the product to the dealer you purchased it from to initiate warranty procedures.

Copyright © 2007 by Perfect Performance Products, LLC